



RADAR BASICS

RADAR BASICS

OSWALDO MASSAMBANI, Ph.D.

Professor

Department of Atmospheric Sciences

Institute for Astronomy, Geophysics and Atmospheric Sciences

University of São Paulo

São Paulo – Brazil

Latin American Nowcasting Workshop - WWRP/WMO

Instituto Nacional de Meteorologia – INMET

Brasilia – DF, Brazil,

03 to 14 November 2003



RADAR BASICS

CONTENT

- ▣ **Historical overview**
- ▣ **Radar systems**
 - remote sensing - radar units
- ▣ **Radar parameters**
 - block diagram, antenna, pulse length, R_{max} range, EM spectra, timing diagram, PRF
- ▣ **Beam propagation**
 - EM propagation - index of refraction - Snell's law, ray-path equation - curvature of the ray-path - range-height equation – non-standard refraction
- ▣ **Scanning strategies**
 - radar data collection strategies
- ▣ **The radar equation**
 - drop-size distribution - rainfall rate - reflectivity
- ▣ **Minimal Detectable Signal**
- ▣ **The ZR conversion**
- ▣ **Attenuation**
- ▣ **Radial velocity**
 - Doppler effect – radial velocity vs. actual velocity - azimuth resolution
- ▣ **Range-velocity ambiguity**
 - $R_{max} \times PRF$ – $V_{max} \times PRF$ – Doppler dilemma
- ▣ **Effects on the Doppler Spectrum**
 - spectral width – Inphase/Quadrature
- ▣ **Ground clutter rejection techniques**
- ▣ **Dual polarization radar**
- ▣ **Dual frequency radar**
- ▣ **Clear air targets**
 - an insect experiment - turbulence
- ▣ **Quality-control of radar reflectivity-rainfall data**
- ▣ **Space based radars**



RADAR BASICS

A HISTORICAL OVERVIEW

Neither a single state nor a single person is able to say, he is the inventor of the radar method.

The radar is a result of an accumulation of many developments and improvements, which scientists of several nations parallelly made share.

There are several milestones with the discovery of important basic knowledge and important inventions.

Driven by the war interests and the general development of the air forces to meaning key players radar technology undergo a strong development push during the 2nd's World War.

After the 2nd World War the radar method is put into "peace use".



RADAR BASICS

- 1865** - The English physicist James Clerk **Maxwell** developed his electric magnetic light theory (Description of the electric magnetic waves and her propagation)
- 1886** - The German physicist Heinrich Rudolf **Hertz** discovers the electro magnetic waves and prove the theory of **Maxwell** with that.
- 1904** - The German high frequency technician Christian Hülsmeyer invents the “**Telemobiloskop**” to the traffic supervision on the water. He measures the running time of electric magnetic waves to a metal object (ship) and back. A calculation of the distance is thus possible. This is the first practical radar test. Hülsmeyer **patented** his invention.
- 1921** - The invention of the **Magnetron** as an efficient transmitting tube by Albert Wallace Hull
- 1922** - A. H. Taylor and L.C.Young of the Naval Research Laboratory (USA) locate a wooden ship for the first time
- 1930** - L. A. Hyland (also of the Naval Research Laboratory), locates an aircraft for the first time
- 1931** - A ship is equipped with radar. As antennae parabolic dishes with horn radiators are used
- 1936** - The development of the Klystron by Metcalf and Hahn. This will be an important component in radar units as an amplifier or an oscillator tube.
- 1940** - Different radar equipments are developed in the USA, Russia, Germany, France and Japan



RADAR BASICS

- 1941** - Radar Meteorology at Radiation Laboratory – MIT
- 1942** - The old B-18s carried the first operational aircraft microwave radar, the S-band SCR-517.
- 1944** - Radar training of the Army Air Corps Weather Officers
- 1944** - Stormy Weather Group in Radar Meteorology at McGill University
- 1946** - Postwar research and development – Weather Radar in the Radar Branch, Signal Corps Laboratories.
- 1946** - The Weather Radar Research Project in the Department of Meteorology of MIT
- 1950** - Weather Radar in the Meteorological Branch, Meteorological Division and Atmospheric Sciences Laboratory, Fort Monmouth USA
- 1954** - First Japanese X-band weather radar built by JRC
- 1954** - Establishment of Meteorological Radar Network in India
- 1958** - British Weather Radars installed in Shanghai and Beijing.
- 1964** - Radar Meteorology at the National Severe Storms Laboratory
- 1977** - First research Weather Radar in São Paulo – Brazil



RADAR BASICS

RADAR SYSTEMS



RADAR BASICS

REMOTE SENSING

PASSIVE

ACTIVE

RADIOMETERS

RADARS

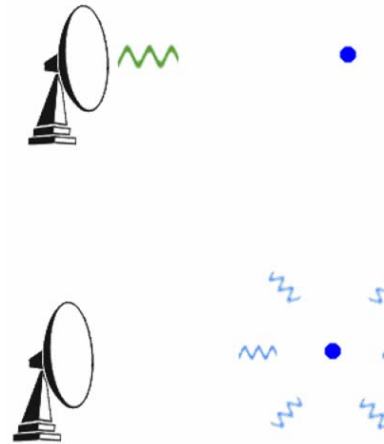
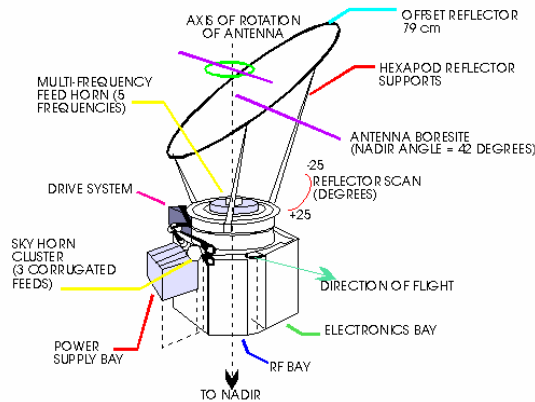

Scanning Multi-channel Microwave Radiometer (SMR)



RADAR BASICS

RADAR

an acronym for

RAdio **D**etection **A**nd **R**anging

Is a radio device or system for detecting and locating a target by means of UHF radio waves.

The EM energy “reflected” from the target is analyzed by the receiving part of the device in such a way that characteristics of the target may be determined.



RADAR BASICS

CLASSIFIED ACCORDING THEIR SPECIFIC FUNCTION

Depending the desired information radar units must have different qualities and technologies.

These different qualities and techniques radar units are classified as:

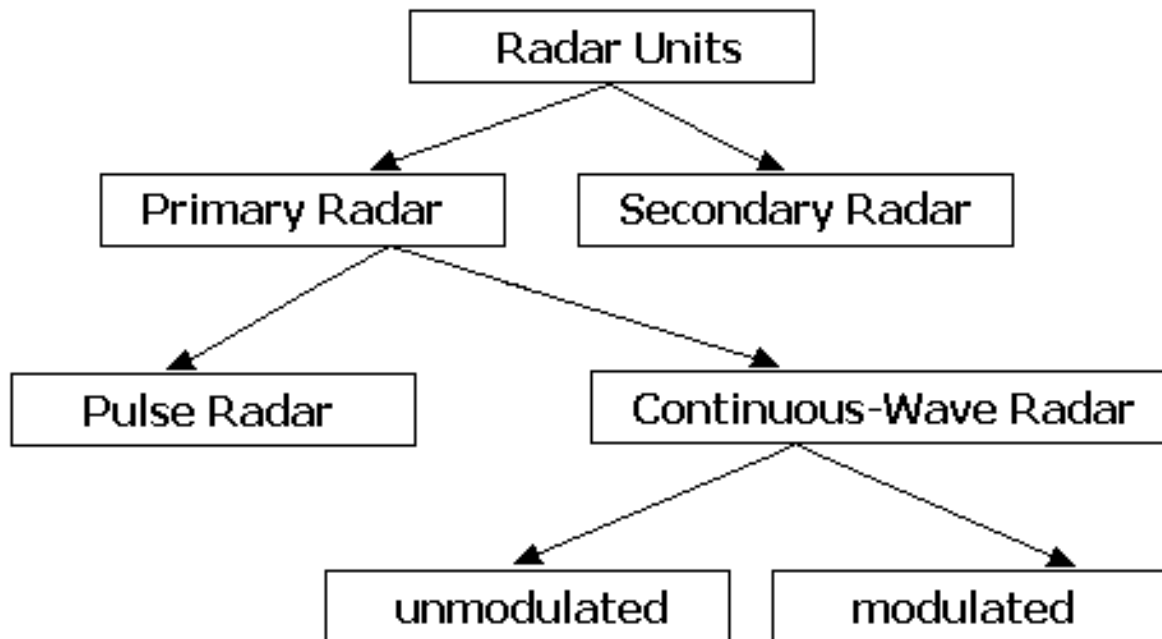



RADAR BASICS

PRIMARY RADAR

A primary radar transmits high-frequency signals which are reflected at targets. The arisen echoes are received and evaluated. This means, unlike secondary radar units a primary radar unit receive her own emitted signals as an echo again.

SECONDARY RADAR

At these radar units the airplane must have a **transponder (transmitting responder)** on board and receives an encoded signal of the secondary radar unit. An active also encoded response signal which is returned to the radar unit then is generated in the transponder. In this response can be contained much more information, as a primary radar unit is able to acquire (E.g. an altitude, an identification code or also any technical problems on board such as a radio contact loss ...).



RADAR BASICS

PULSE RADARS

Pulse radar is a primary radar unit which transmit a high-frequency impulsive signal of high power.

After this a longer break in which the echoes can be received follows before a new transmitted signal is sent out.

Direction, distance and sometimes if necessary the altitude of the target can be determined from the measured antenna position and propagation time of the pulse-signal.



RADAR BASICS

Conventional Weather Radars (non Doppler)

A conventional weather radar can be defined as an early, non-Doppler weather radar system which uses less efficient clutter elimination processing (such as clutter map and statistics) than modern systems. Although there are still several conventional weather radar systems in operation, these are no longer manufactured.

Doppler Weather Radars

Is a type of radar which measures the change in frequency of the return signal to determine if targets are moving towards or away from the radar station. Objects moving tangentially to the radar have no change in frequency and show no return on Doppler Radar. **COHERENT** radars provide detection of the phase difference between the outgoing and return pulses. **NON-COHERENT** radars are unable to measure the difference between the outgoing pulse and the return pulse.

Polarimetric Doppler Weather radars

Polarimetric Radars are Doppler weather radars with additional transmitting and processing functionality to allow to further compute additional information on the directionality of the reflected electromagnetic energy received.

Conventional, Doppler and Polarimetric weather radars are all operational systems and they operate in C-band, S-band or X



RADAR BASICS

CONTINUOUS- WAVE RADAR

CW radar units transmit a high-frequency signal continuously.

The echo signal permanently is received and processed.

The receiver needn't be mounted at the same place as the transmitter absolutely. Every firm civil radio transmitter can work as a radar transmitter at the same time, if a remote receiver compares the propagation times the direct one with the reflected signal.

Tests are known that the correct location of an airplane can be calculated from the evaluation of the signals by three different television stations.



RADAR BASICS

Unmodulated CW- Radar

The transmitted signal of these equipments is constant in amplitude and frequency. These equipments are mostly used in speed measuring. Distances cannot be measured. In general are used as speed gauges of the police.

Modulated CW- Radar

The transmitted signal is constant in the amplitude but modulated in the frequency. This uses the principle of the propagation time measurement. The advantage of these equipments is that the measurement result is continuously available. These radar units are used everywhere there where the measuring distance isn't too large and it's necessary a continuous measuring (e.g. an altitude measuring in airplanes or as weather radar/wind profiler). A similar principle of obtaining is also used by radar units whose transmitting impulse is too long to get a well distance resolution.

Bistatic Radar Sets

A bistatic radar consists of a separated transmitting and receiving sites by a considerable distance.



RADAR BASICS

Characteristic	Primary Surveillance Radar	Weather Radar
FREQUENCY	L, S-band	S,C & X-band (+L-band)
DOPPLER	yes	yes
SCANNING	Azimuth or Elevation	Azimuth and Elevation
PROCESSING	Complex & real-time	Very complex, not time-critical
POLARISATION	Linear and Circular	Dual (vertical and horizontal)
PEAK POWER	Various (kW - Mw)	Various (kW - Mw)
PROCESSING	I (inface) & Q (quadrata)	I & Q
"PICTURE"UPDATE	6 - 12 seconds	5 - 15 minutes
CLUTTER PROCESSING	Yes (but weather is clutter)	Yes (but aircraft are clutter)
ANTENNA SIZE	Larger (longer wavelength)	smaller (shorter wavelength)



RADAR BASICS

RADAR PARAMETERS



RADAR BASICS

Pulse width (τ) The transmission time of the pulse (usually measured in microseconds). Also called the pulse duration.

Pulse repetition frequency (PRF) The number of pulses transmitted in a given time (usually measured in pulses per second).

Peak power (P_t) The maximum power of the pulse (measured in Watts).

Wavelength (λ) The wavelength of the radio wave transmitted by the radar. For weather radars this is in the microwave region (wavelengths of 3 to 10 cm are common).

Beamwidth (θ) The angular width of the radar beam.

Antenna area (A_e) The area of the antenna aperture.

For a given beamwidth, as the wavelength increases a larger antenna area is required. Thus, a radar operating at a wavelength of 10-cm radar will have a larger antenna than one operating at 3-cm.

Antenna gain (G) The ratio of the radiance in the beam (L) versus the isotropic radiance (L_0)



RADAR BASICS

BLOCK DIAGRAM OF A SIMPLE RADAR

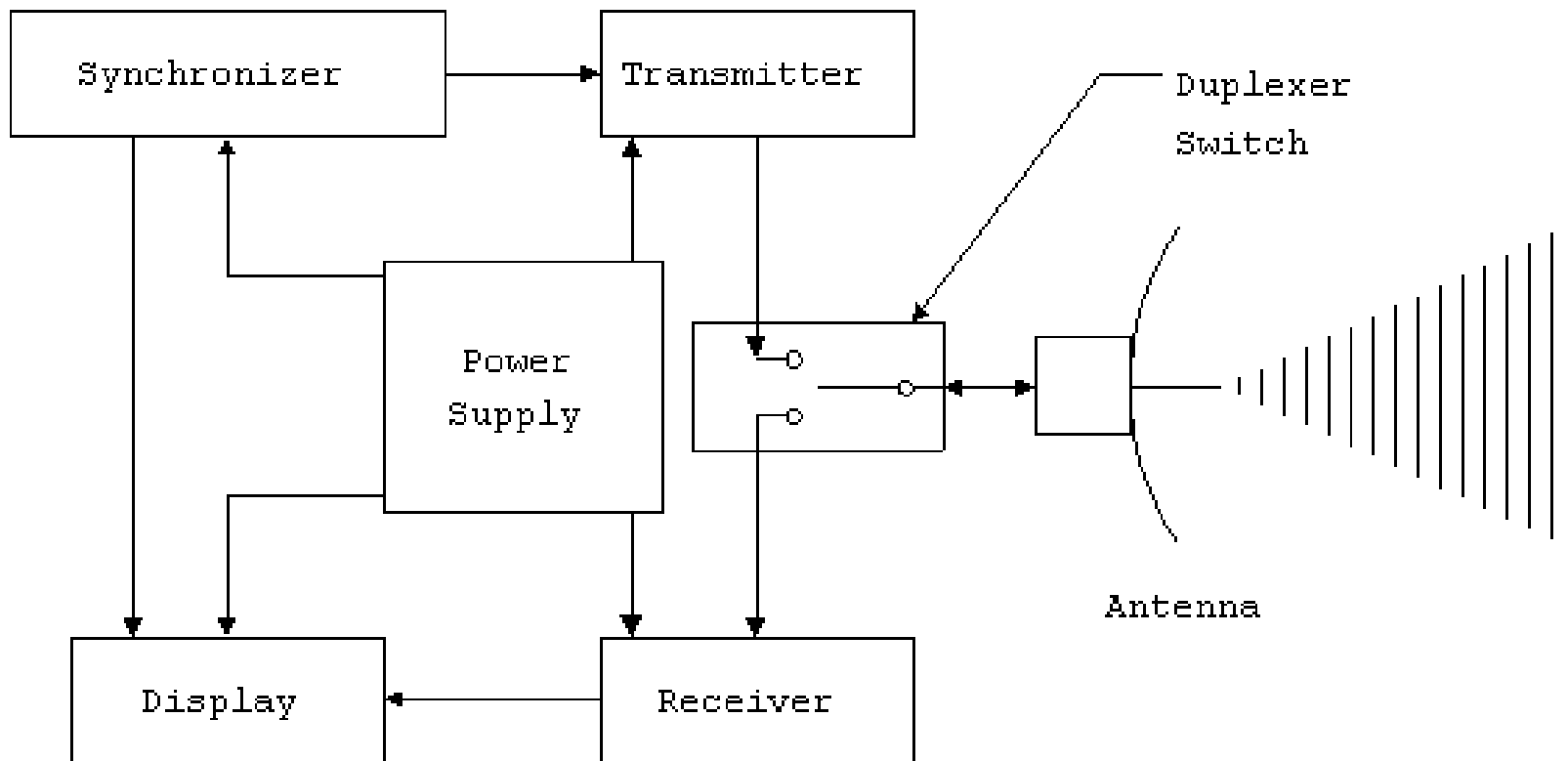



RADAR BASICS

RADAR ANTENNA and RADAR BEAMWIDTH

Parabolic antenna model

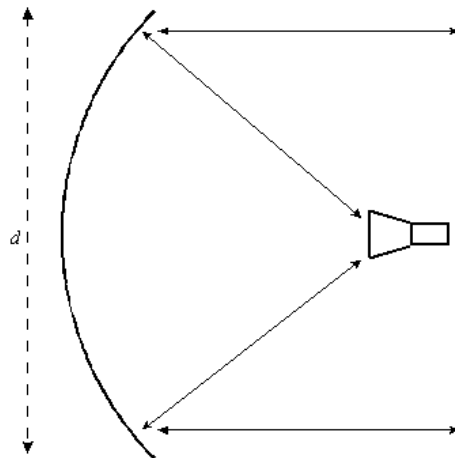

Strong Thunderstorm

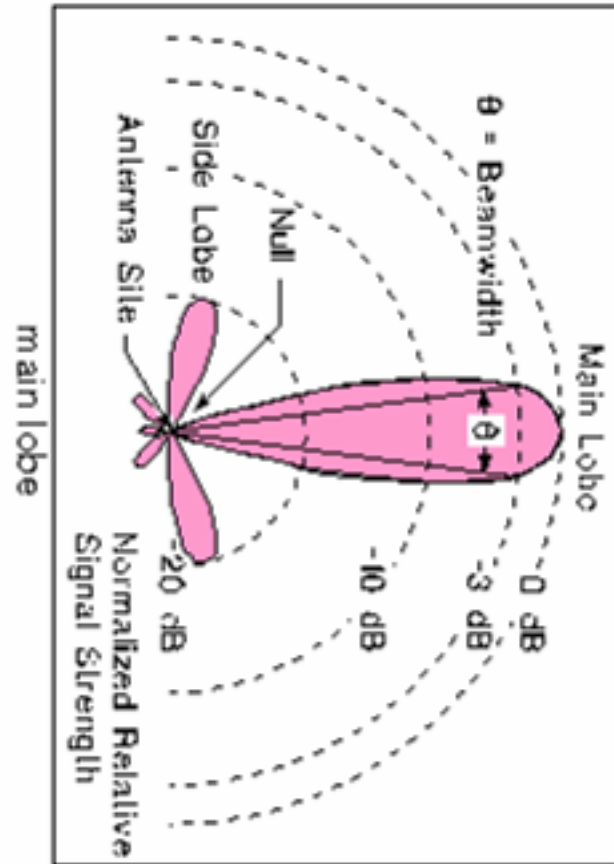
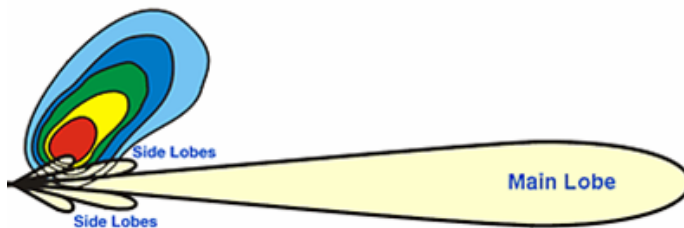



RADAR BASICS

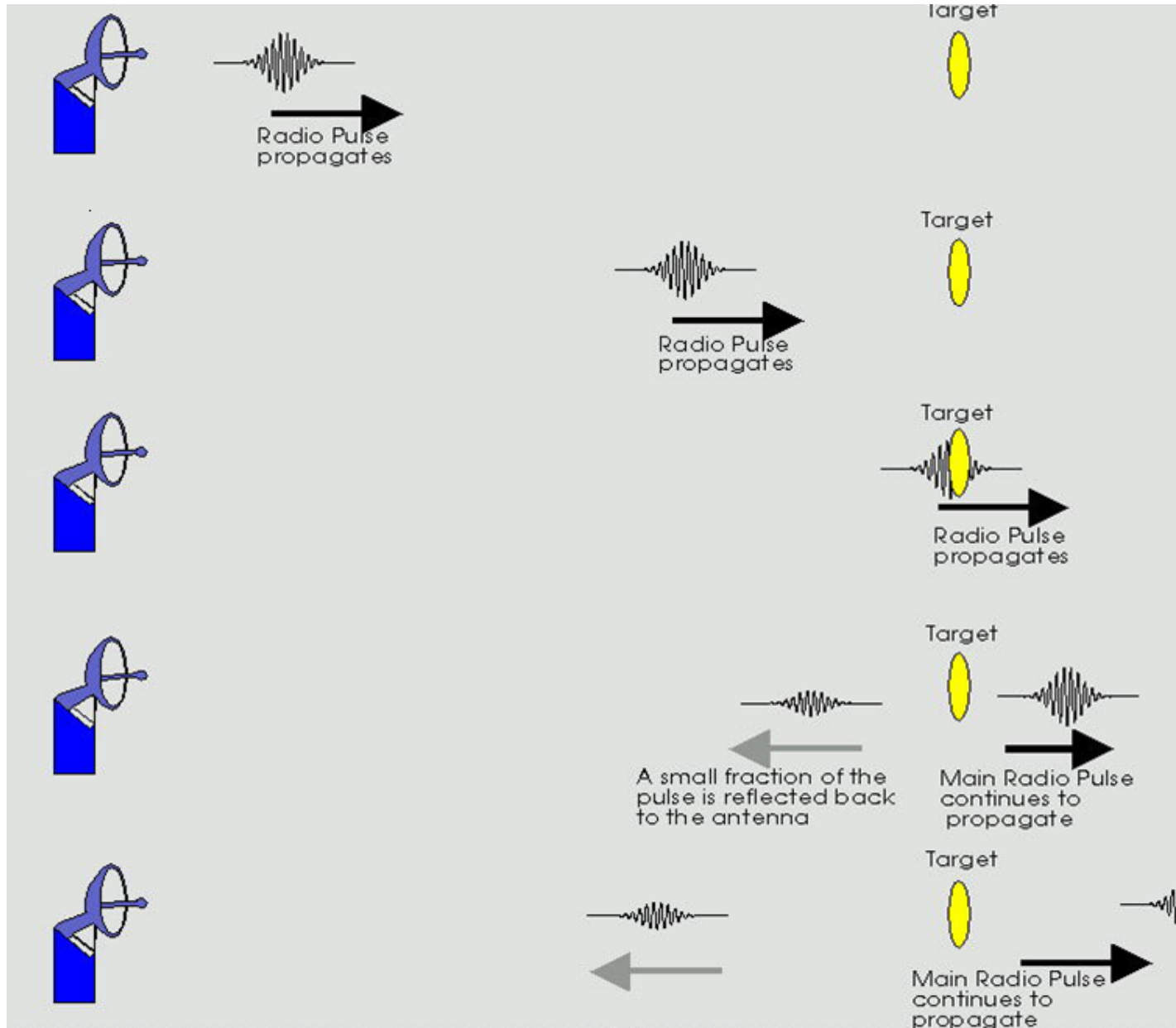



RADAR BASICS

The **GAIN** is dimensionless, and is greater than 1

$$G \equiv L/L_0$$

The **GAIN** is a function of wavelength and antenna area, and is approximated by

$$G \cong 4\pi A_e / \lambda^2$$

The **MAXIMUM UNAMBIGUOUS RANGE** of a radar is a function of the pulse repetition frequency. The lower the PRF, the larger the maximum unambiguous range. The maximum unambiguous range is given by

$$r_{\max} = c/2PRF$$

The **MINIMUM RANGE OF A RADAR** is a function of the pulse width, since the radar cannot detect a return pulse while it is transmitting. The minimum range is

$$r_{\min} = c\tau/2$$



RADAR BASICS

DETERMINING THE PULSE LENGTH

An example:

For a Pulse duration of **1.57 μ s** and **4.7 μ s** and considering the **Speed of light**: 300 meters per microsecond

Pulse Length = Pulse duration μ s X 300 m μ s⁻¹

The pulse length are: **471 m** and **1410 m**

Pulse length will be equivalent to the "length" of each "bin" for which the data is collected. It determines the range resolution.

- o Pulse creates a BIN volume: length times width and height
- o Better resolution with shorter duration



RADAR BASICS

DETERMINING THE MAXIMUM RADAR RANGE

An example:

With a PRF of 500 pulses per second (pps), which correspond to a pulse every 2000 μs

Pulse travels $2000\mu\text{s} \times 300\text{m } \mu\text{s}^{-1} = 600,000 \text{ m}$ or 600 km

Maximum Range is 300 km, given equal time for a return echo to come back to the radar

NEXRAD PRF's:

318 Hz & 1304 Hz both at 1.57 μs and
452 Hz at 4.7 μs lengths

Conclusion:

higher PRF, shorter range;
lower PRF = longer range



RADAR BASICS

EM SPECTRUM

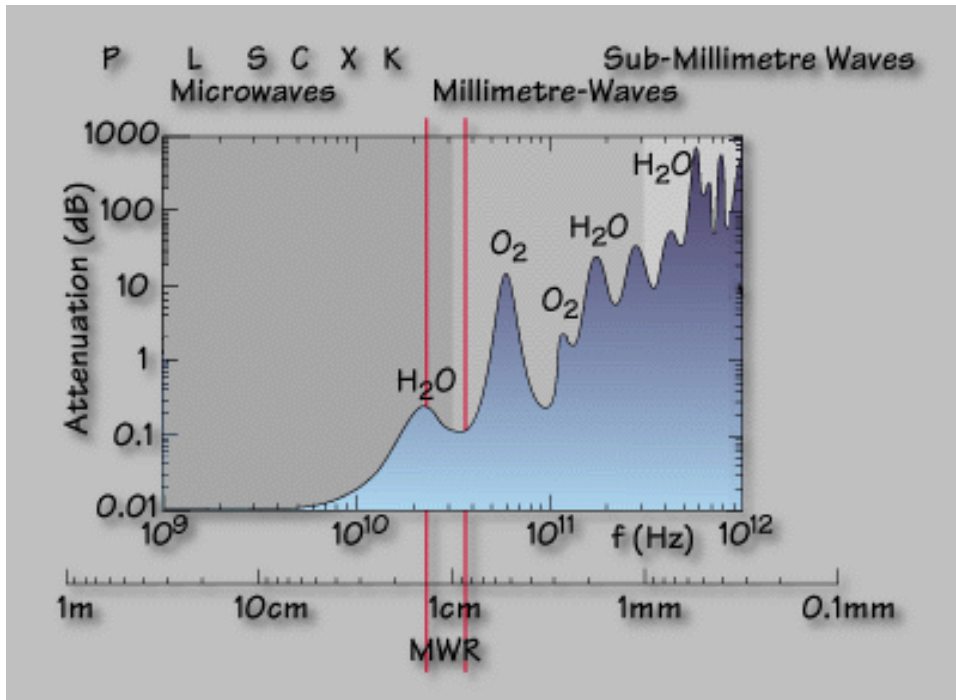
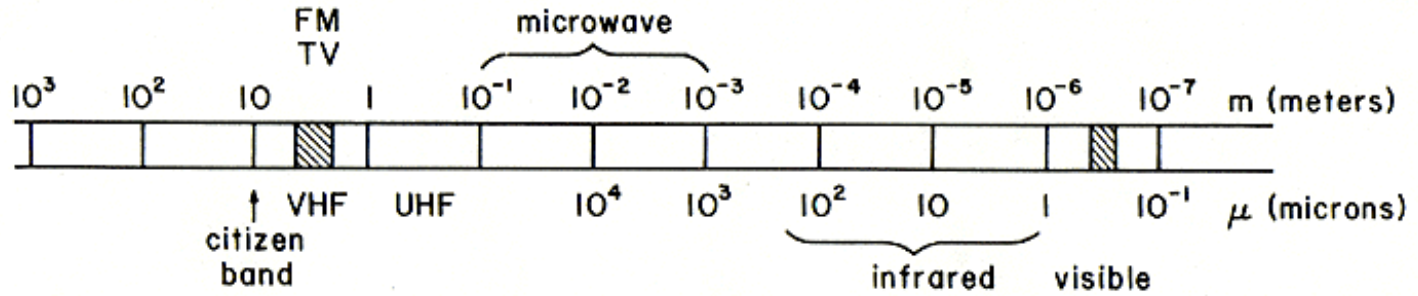

<u>Frequency Band</u>	<u>Frequency (MHz)</u>	<u>Wavelength range (cm)</u>	<u>Meteorological typical</u>
UHF	300-1000	30-100	Profiler
L	1000-2000	15-30	
S	2000-4000	7.5-15	10 cm
C	4000-8000	4-7.5	5 cm
X	8000-12500	2.5-4	3 cm
K	> 12500	about 1	8 mm



RADAR BASICS

RADAR WAVELENGTH

- **Radar signals are EM waves and, as such, have a wavelength given by,**

$$\lambda = \frac{c}{f_0}$$

where,

λ wavelength (m)

c speed of light (m/sec)

f_0 transmit frequency of radar (Hz)

- **The wavelength is one of the most important factors influencing the radar imagery characteristics**



RADAR BASICS

TIMING DIAGRAM

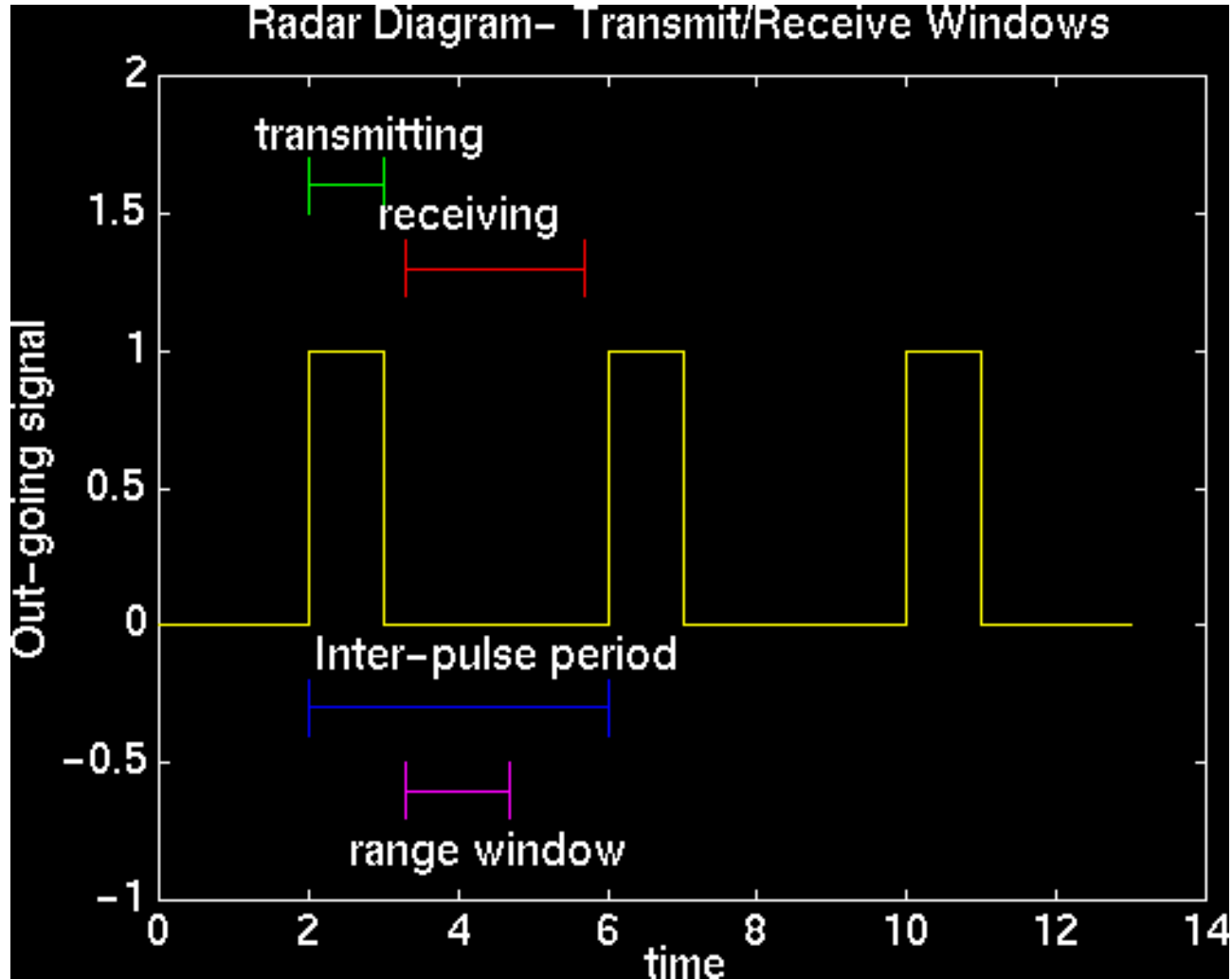



RADAR BASICS

Pulse Repetition Frequency

Pulse Repetition Frequency (PRF) is the number of pulses transmitted per second by the radar. The reciprocal of this is called the **Pulse Repetition Time (PRT)**, which is the elapsed time from the beginning of one pulse to the beginning of the next pulse.

PRF is important since it determines the maximum target range (R_{\max}) and maximum Doppler velocity (V_{\max}) that can be accurately determined.

PRF & PRT			
PRF (s^{-1})	PRT (msec)	PRF (s^{-1})	PRT (msec)
250	4.0	1000	1.0
500	2.0	1250	0.80
750	1.3	1500	0.67

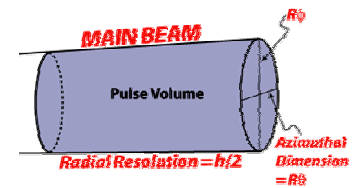
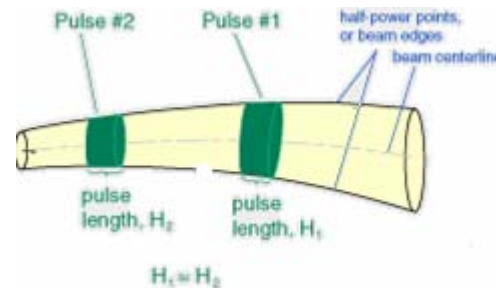
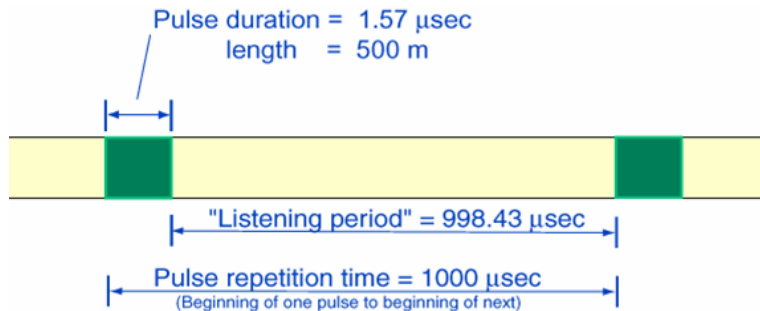



RADAR BASICS

BEAM PROPAGATION



RADAR BASICS

RADAR BEAM PROPAGATION

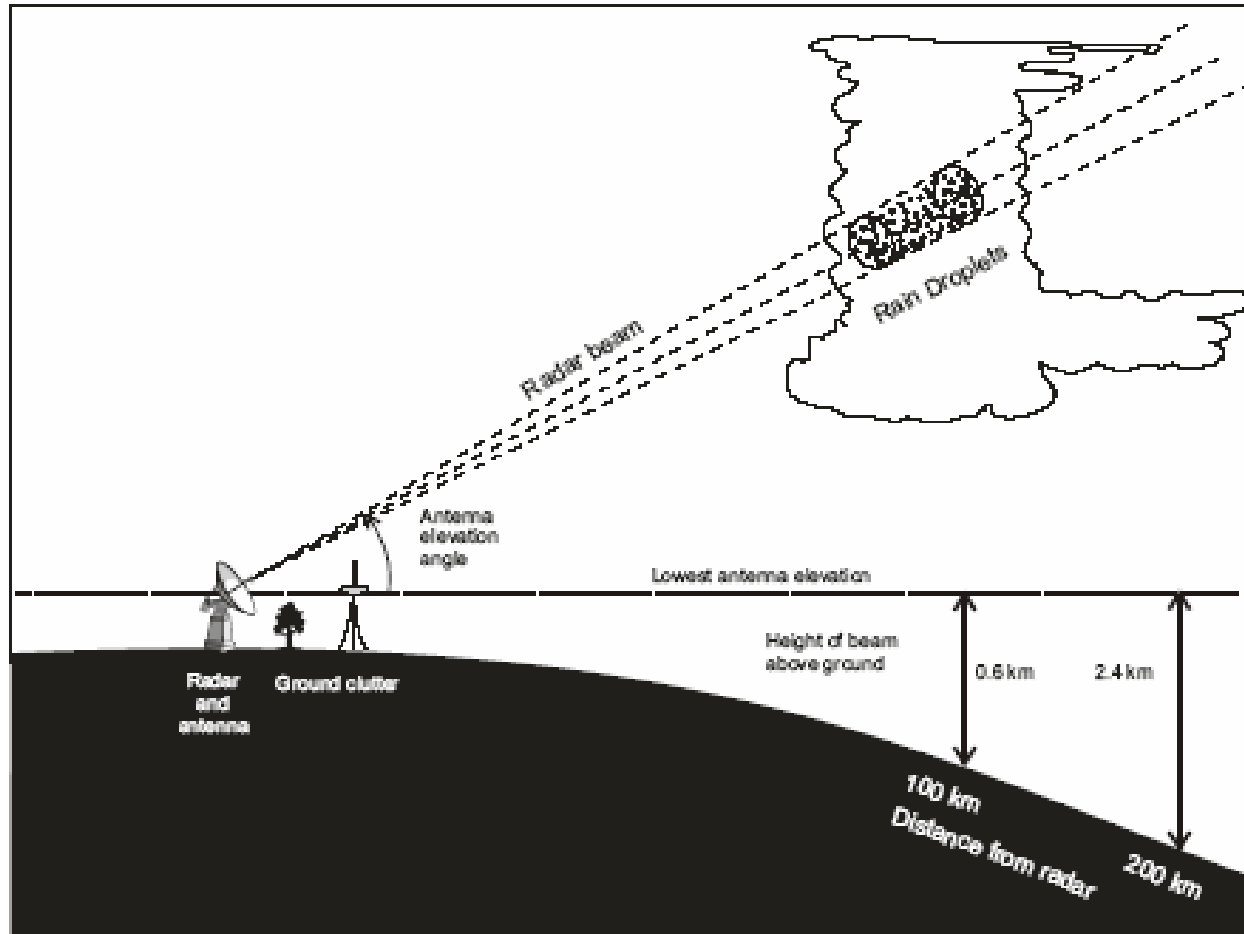

Radar scans this entire volume by raising and lowering the beam as the antenna rotates.



RADAR BASICS

To determine the location of the radar beam, it is necessary to calculate the height (above the height of the radar antenna feed horn) of the radar beam centerline assuming a **standard atmosphere**.

If the atmosphere deviates from standard refractive conditions, the radar beam also deviates from its assumed or **normal** propagation path.

In other words, it refracts or bends just like a beam of light propagating through different media and can either **sub refract** or **super refract**. The following figure is an illustration of the various beam propagation paths.

Ducting is an extreme case of super refraction condition such that the radar beam gets trapped or “ducted” within a stable layer or temperature inversion layer.

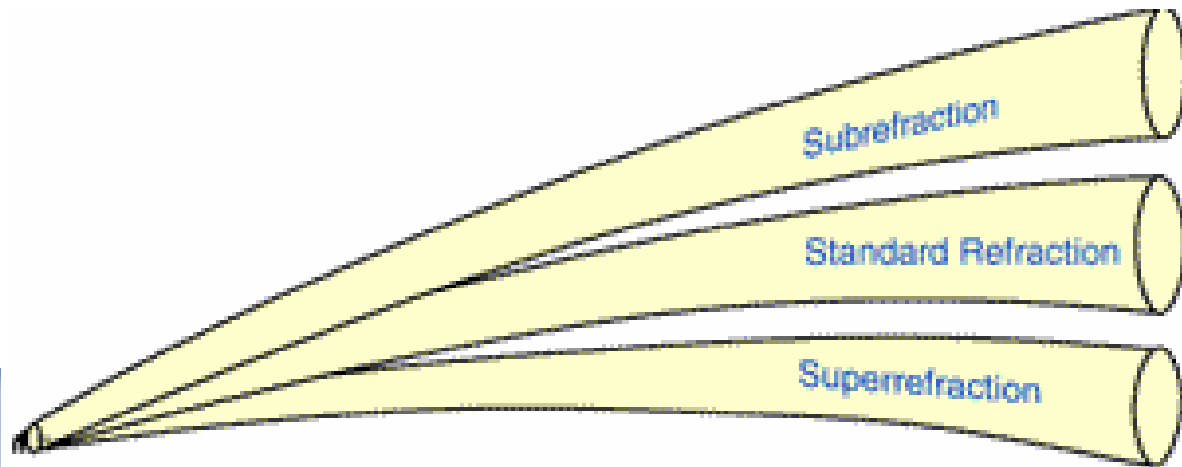



RADAR BASICS

PROPAGATION OF ELECTROMAGNETIC WAVES

In this section we will discuss the propagation of EM waves including further discussions on the index of refraction, Snell's Law, and derivation of equations for the ray path of a radar wave traveling under various atmospheric conditions.

Since the atmosphere is a non-vacuum, we deal with wave speeds that are different from the speed of light, $c = 2.998 \times 10^8$ m/s. As discussed in the previous section, the wave speed for a non-vacuum defines the index of refraction, $n = c/v$ where v is the wave speed in the particular medium. Since $c = \sqrt{\epsilon_0 \mu_0}$ and $v = \sqrt{\epsilon_1 \mu_1}$, we have

$$n^2 = \epsilon \mu \quad \text{where } \epsilon = \epsilon_1 / \epsilon_0 \text{ and } \mu = \mu_1 / \mu_0$$

Since μ is approximately 1 for most media considered, $n^2 = \epsilon$. With $\epsilon > 1$, $n > 1$ and hence $v < c$ (by a small amount). The general form of the index of refraction is of the form

$$m = n - ik$$

where k is the absorptivity of the medium.



RADAR BASICS

Index of refraction

The atmosphere is an inhomogeneous medium, with variations in temperature, pressure and water vapor, all of which contribute to changes in the index of refraction.

Index of refraction for the atmosphere-governs the path of radar waves

Index of refraction for dry air, or **N, the refractivity**

For dry air, $N = (n-1)10^6 = k_1 p/T$ where P is in mb, T in °K, $k_1 = 77.6$ (°K/mb)

Substituting from the Ideal Gas Law,

$$(n-1) 10^6 = K_1 R \rho = \text{constant} \times \rho$$

Therefore, $dn/dz \approx d \rho/dz$



RADAR BASICS

Water vapor contribution to the index of refraction (n)

Since air molecules essentially have no permanent dipole moment, **N** does not vary with frequency. However, this is not the case for the water vapor molecule, which has a permanent dipole moment. The degree of alignment of this dipole moment with the incident E field vector is frequency dependent. For microwave frequencies,

$$\mathbf{N} = (\mathbf{n}-1)10^6 = \mathbf{K}_3\mathbf{e}/\mathbf{T}^2 - \mathbf{K}_2\mathbf{e}/\mathbf{T}$$

where e is the vapor pressure in mb; $K_2 = 5.6 \text{ }^\circ\text{K}/\text{mb}$; $K_3 = 3.75 \times 10^5 \text{ } (^\circ\text{K})^2/\text{mb}$

Index of refraction may be found by adding components for both dry air and water vapor,

$$\mathbf{N} = \mathbf{K}_1\mathbf{p}/\mathbf{T} + \mathbf{K}_3\mathbf{e}/\mathbf{T}^2 - \mathbf{K}_2\mathbf{e}/\mathbf{T}$$

Key question: How does N vary with height and with varying atmospheric conditions?



RADAR BASE

Snell's Law

First examine simple refraction in terms of **Snell's Law**

Since ρ and e decrease exponentially with height, n decreases with altitude (these effects offset the linear decrease in height for T , for most situations). Since $n = c/v$, v increases with height and hence the wave is bent downward. Snell's Law is

$$\sin i / \sin r = v_i / v_r$$

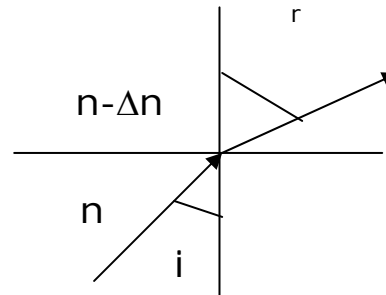

since $v_r > v_i$ it follows that $\sin r > \sin i$ and hence $r > i$

This is the typical situation for a ray path in the atmosphere under conditions where the temperature decreases with height.



RADAR BASICS

RAY PATH EQUATION SPHERICALLY-STRATIFIED ATMOSPHERE

For dn/dh small, Hartee, Michel and Nicolson (1946) derived an exact differential equation for a radar ray path in a spherically-stratified atmosphere.

$$\mathbf{d^2h/ds^2} - (2/(R+h) + 1/n(dn/dh))(dh/ds)^2 - ((R+h)/R)^2 (1/(R+h) + 1/n(dn/dh)) = 0 \quad (1)$$

where $\mathbf{d^2h/ds^2}$ is the curvature of the ray path. Under most conditions, the following assumptions can be made:

$$(dh/ds)^2 \ll 1$$

$$n \approx 1$$

$$h \ll R$$

With these assumptions, (1) reduces to

$$\mathbf{d^2h/ds^2} = 1/R + dn/dh \quad (2) \text{ Here } d^2h/ds^2 \text{ is the curvature of the ray path.}$$



RADAR BASICS

Consider the geometry for a ray path in the Earth's atmosphere. Here R is the radius of the Earth, h_0 is the height of the transmitter above the surface, φ_0 is the initial launch angle of the beam, φ_h is the angle relative to the local tangent at some point along the beam (at height h above the surface at great circle distance s from the transmitter).

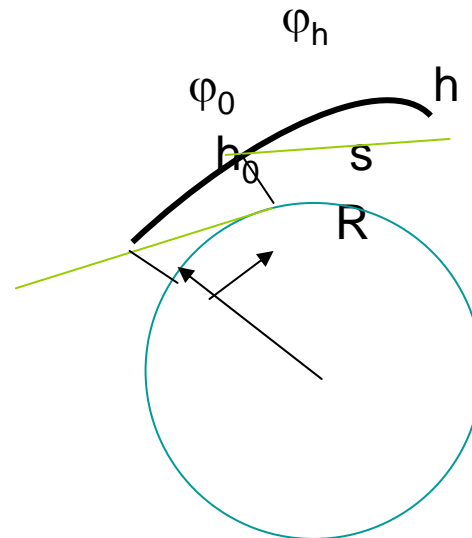



RADAR BASICS

Integrating (2) yields,

$$(dh/ds)^2 = 2 \int (1/R + dn/dh) dh + \text{constant} \quad (3)$$

Since $dh/ds \approx \varphi$ for small φ , (3) can be written as,

$$\begin{aligned} 1/2(\varphi_h^2 - \varphi_0^2) &= (h - h_0)/R + n - n_0 \\ &= (h/R + n) - (h_0/R + n_0) \end{aligned}$$

Letting $M = [h/R + (n-1)] \times 10^6$, we have

$$= (M - M_0) 10^{-6}$$

M is the so-called **modified index of refraction**. M has a value of approximately 300 at sea level.



RADAR BASICS

Curvature of Ray Paths Relative to the Earth

If the vertical profile of M is known (say through a sounding yielding p , T and q), φ_h can be calculated at any altitude h , that is, the angle relative to the local tangent.

Lets now consider the ray paths relative to the Earth. For the case of no atmosphere, or if N is constant with height ($dN/dh = 0$), the ray paths would be straight lines relative to the curved Earth.

$$d\varphi/ds = 1/R + dn/dh$$

$1/R$ for n constant with height

For n varying with height,

$$d\varphi/ds = 1/R + dn/dh$$

$< 1/R$ since $dn/dh < 0$

For the special case where $dn/dh = -1/R$, $d\varphi/ds = 0$. Hence the ray travels around the Earth concentric with it, at fixed radius, $R + h$. This is the case of a **trapped wave**. **" DUCTING "**



RADAR BASICS

Range-Height Equation

For convenience, it is easier to introduce a fictitious Earth radius,
 $1/R' = 1/R + dn/dh$

For typical conditions, $dn/dh = -1/4 R^{-1}$

Hence **$R' = R/(1 - 1/4) = 4/3 R$**

This is the effective earth radius model.

Doviak and Zrníc (1993) provide a complete expression for h vs. r , where r is the slant range (distance along the ray).

$$h = \{r^2 + (k_e R)^2 + 2rk_e R \sin\theta\}^{1/2} - k_e R + h_0$$

where h is beam height as slant range r , θ is the elevation angle of the antenna, and k_e is $4/3$ (R is the actual Earth radius).

Important to note that, for radar sites not located at sea-level, the height (h_0) of the antenna feed horn above sea-level must be added to the computed beam centerline height to convert the ARL height to sea-level reference (ASL).



RADAR BASICS

Refraction Models

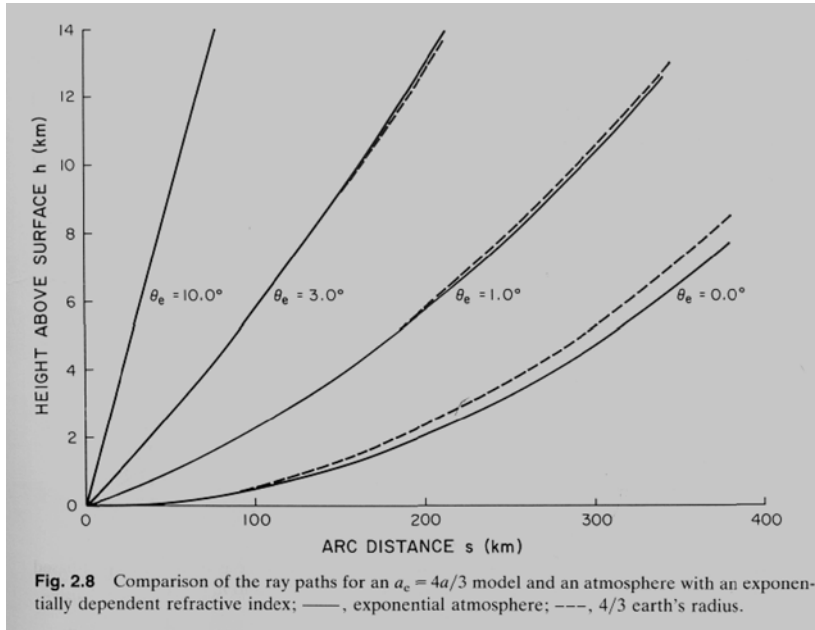

Non-standard refraction model

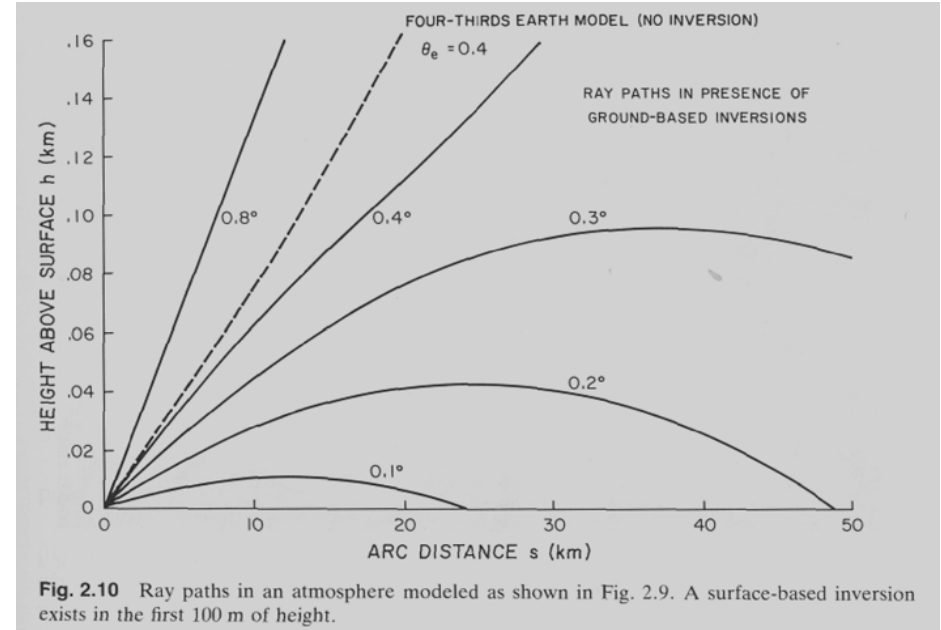

Doviak and Zrníc (1992)



RADAR BASICS

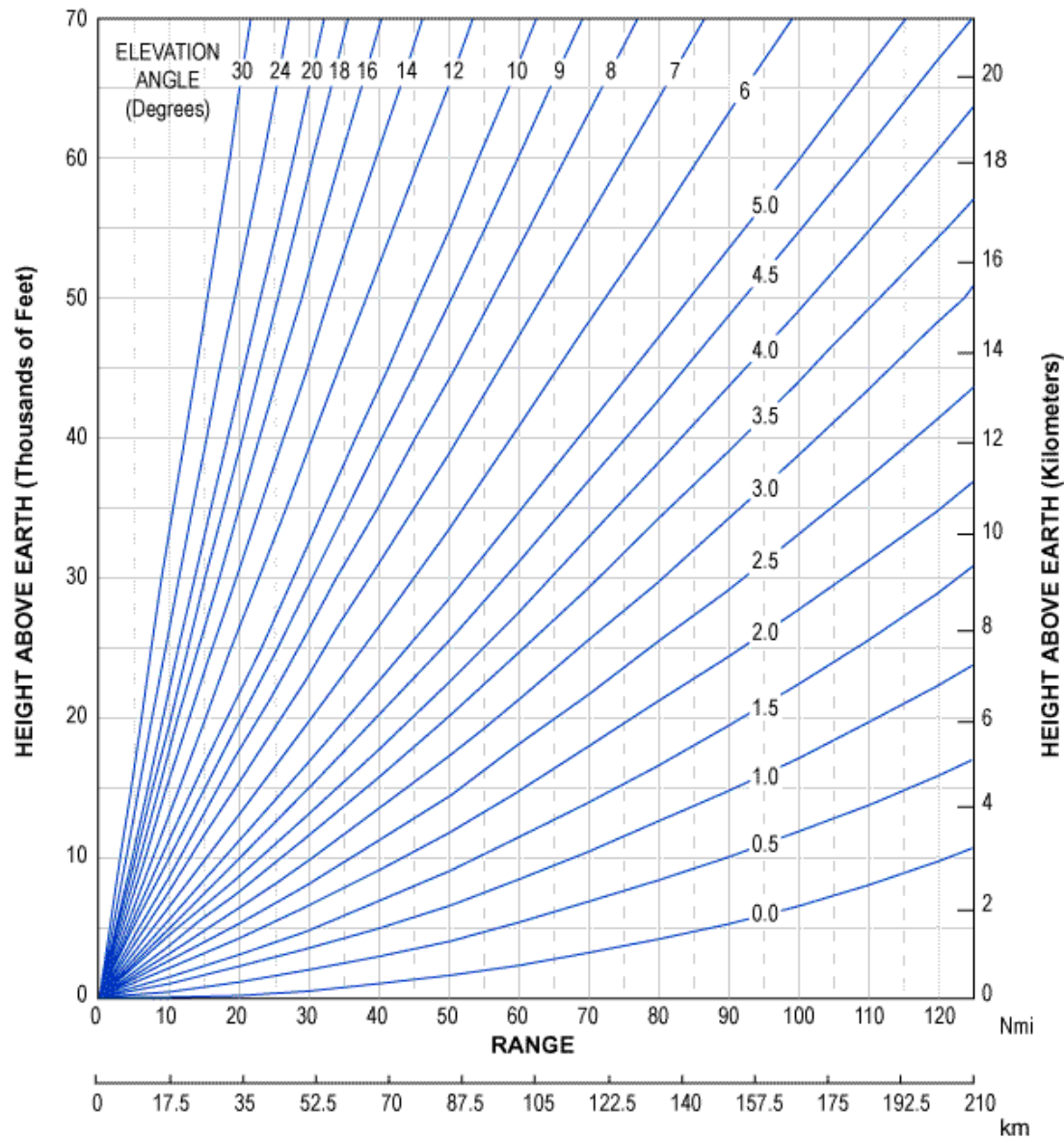

Range vs. Height graph of beam center height under normal or standard refractive conditions



RADAR BASICS

Non-standard refraction typically occurs with the temperature distribution does not follow the standard lapse rate ($dn/dh \neq -1/4 (R)$). As a result, radar waves may deviate from their standard ray paths predicted by the previous model. This situation is known as abnormal or anomalous propagation.

**Abnormal downward bending
(most common type of AP)**

super refraction

Abnormal upward bending

sub refraction

Superrefraction is associated most often with cold air at the surface, giving rise to a near surface elevated temperature inversion in which the T increases with height. Most commonly caused by radiational cooling at night, or a cold thunderstorm outflow.

Since T increases with height, n decreases (rapidly) with height (dn/dh is strongly negative).

Since $n = c/v$, v must increase with height, causing downward bending of the ray path.



RADAR BASICS

NON-STANDARD REFRACTION

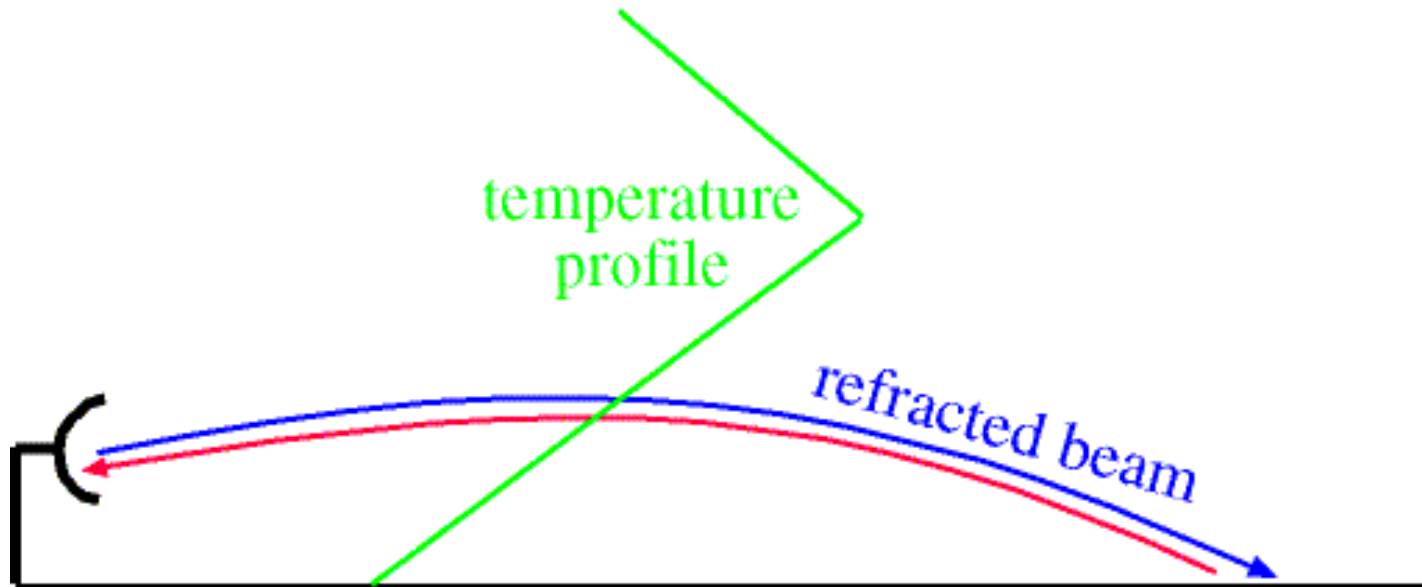



RADAR BASICS

SCANNING STRATEGIES



RADAR BASICS

AZIMUTH – ELEVATION – RANGE

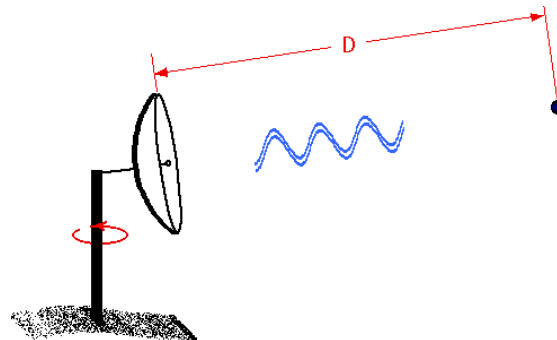
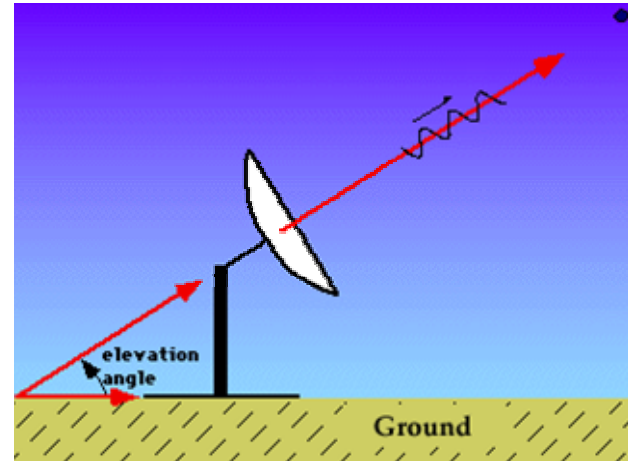
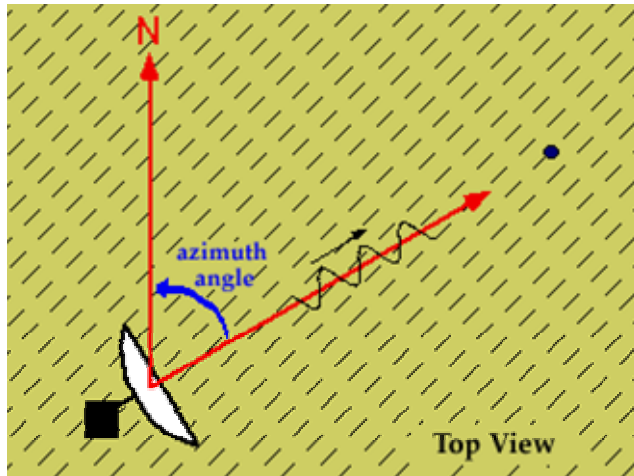



RADAR BASICS

VOLUME COVERAGE PATTERN

Is a series of consecutive scans, either around the horizon or in a sector, that together sweep out a volume of space. Volume scans are typically performed by conducting a series of horizontal scans, each at a progressively higher elevation angle.

A less common method is to conduct a series of vertical scans between the horizon and the zenith, each at a different azimuth angle.

Volume scans are used to develop three-dimensional views of the reflectivity field and, in a Doppler radar, the radial velocity field associated with the targets illuminated by the radar.

A Volume Coverage Pattern is a series of 360 degree sweeps of the antenna at selected elevation angles completed in a specified period of time. Four separate scan strategies are used now with the possibility of others being implemented in the future.



RADAR BASICS

HEIGHT x SLANT RANGE

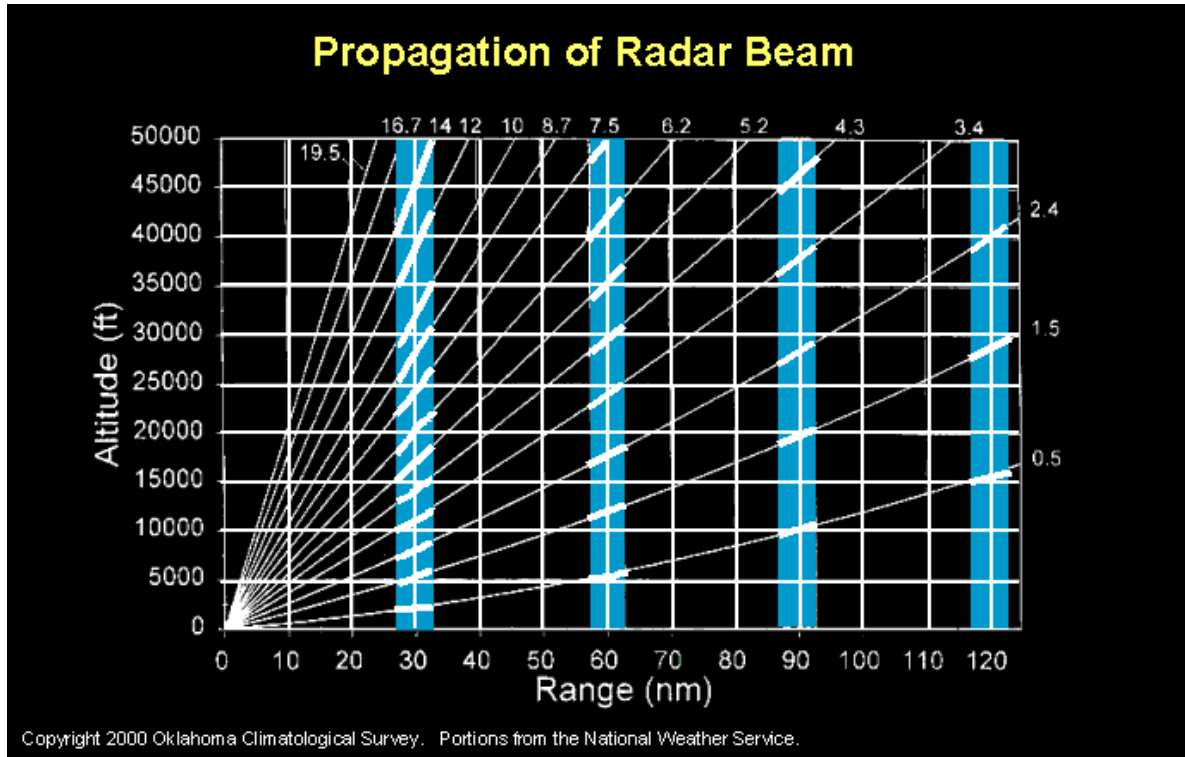
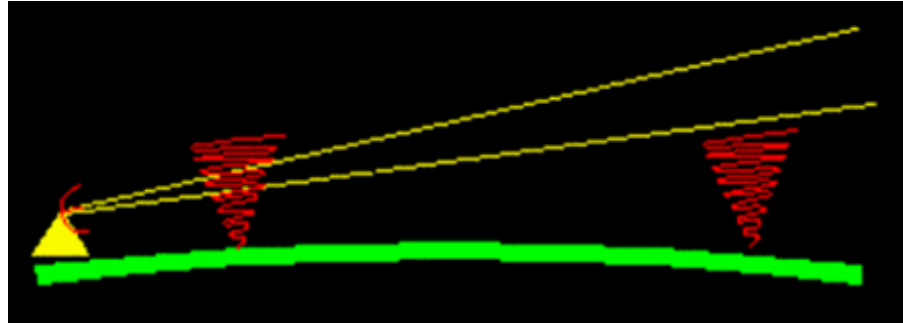



RADAR BAS

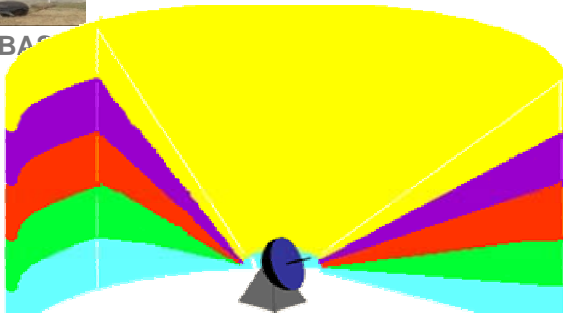

A cross section of a Clear Air Mode Volume Scan

The different colors represent scans at different elevation angles.

The scans form a cylindrical stack of cones.

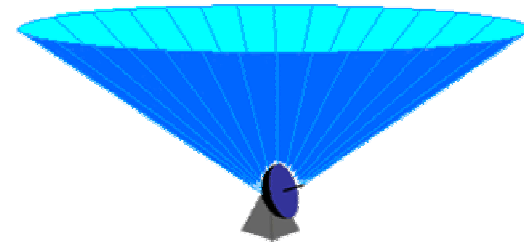

PPI displays the data from one elevation angle (the surface of the cone)

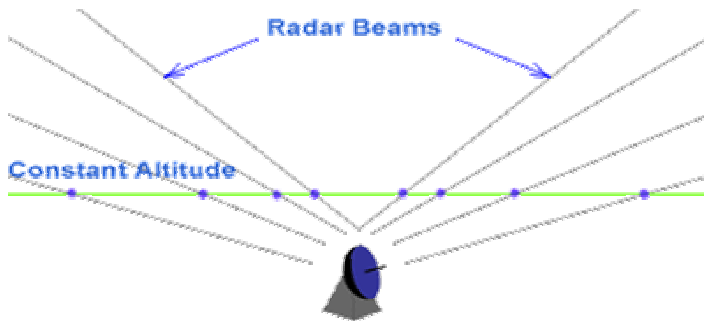

CAPPI combines data from many different elevation angles

CAPPI: Constant Altitude PPI, is a PPI style display which merges the data from different elevation volume scans to give a picture of the area radiating outward from the radar station at a constant altitude (recall that on a normal PPI, the farther from the center of the screen, the higher the altitude of the return).

There are two main types of modes used by radar stations to detect weather patterns: **Clear Air Mode** and **Precipitation Mode**.



RADAR BASICS

RADAR DATA COLLECTION STRATEGY

To adequately sample the atmosphere the weather surveillance radars employ several scanning strategies or volume coverage patterns.

Volume Scan – is a radar scanning strategy in which sweeps are made at successive antenna elevations (i.e., a tilt sequence), and then combined to obtain the three-dimensional structure of the echoes

The lowest seven angles are contiguous. The resulting data are used in algorithms to determine storm tracks, shear and mesocyclones. Other algorithms compute precipitation amounts and wind profiles.

Scanning - Is the motion of the radar antenna during data collection. Scanning usually follows a systematic pattern involving one of the following:

In horizontal scanning, used to generate PPI displays, the antenna is continuously rotated in azimuth around the horizon or is rotated back and forth in a sector (sector scanning) at the completion of each 360 or sector scan, the elevation angle of the scan typically is increased;

Vertical scanning, used to generate RHI displays, is accomplished by holding the azimuth constant while continuously varying the elevation angle of the antenna; at the completion of each vertical scan, the azimuth typically is incremented and the vertical scan proceeds in the opposite direction.



RADAR BASICS

Clear air mode:

Is a radar operation mode. In this mode, scans are made at five different elevations starting at 0.5° and incrementing by 1° for each elevation.

Two full rotations are made at each elevation. Images are updated every ten minutes. This increases the radar's ability to detect small objects in the atmosphere. Most of what the radar detects in this mode will be airborne dust and particulate.

Is used to detect early formation of convective precipitation, air mass discontinuities and to obtain wind profiles.

It uses a long pulse and sweeps 5 elevation angles in 10 minutes. There are separate surveillance and Doppler scans on the lowest three elevation angles.

The radar starts at an elevation angle of 0.5° and performs volume scans at 5 different elevation angles (Fig F1). Each subsequent elevation is 1° higher than the last (so scans are taken at 0.5° , 1.5° , 2.5° , 3.5° and 4.5°).

At each elevation angle, the radar makes two full azimuthal rotations. One rotation is to collect reflectivity data and the other is to collect Doppler data.

It takes approximately 10 minutes for the radar to complete the scans at all 5 elevations. Because snow has a low reflectivity, this mode will sometimes be used to detect light snowfall.



RADAR BASICS

Precipitation Mode:

Is a radar operation mode. In this mode, scans are made at fourteen different elevations starting at 0.5° and increasing up to 19.5° . Two full rotations are made at each elevation.

At lower elevations, scans are typically separated by 1° ; however at higher elevations scans are separated by larger increments leaving gaps in the volume scan.

The antenna rotation is considerably faster and the sensitivity of the scan is lower than Clear Air mode. However, much higher elevation volume scans are given allowing for analysis of the vertical structure of storms.

Is used as a precipitation mode strategy, which uses a short pulse wave and sweeps about 14 elevation angles in 5 minutes.

In general the RADAR uses separate surveillance and Doppler scans at the 2 lowest angles: The two lowest elevation angles are scanned once for reflectivity and a second time for velocity.

A second precipitation mode strategy, is used to observe more distant storms; it uses a short pulse and sweeps 9 elevation angles in 6 minutes.

There are separate surveillance and Doppler scans at the two lowest elevation angles with the lowest five angles being contiguous.



RADAR BASICS

Volume Scanning Patterns

Precipitation Mode

Clear Air Mode

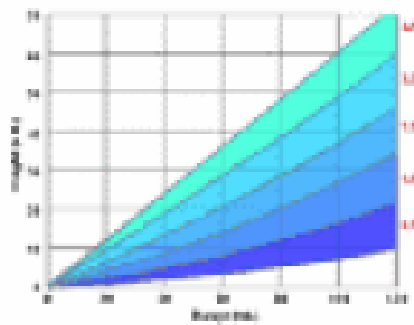

10 min

Slow Scan

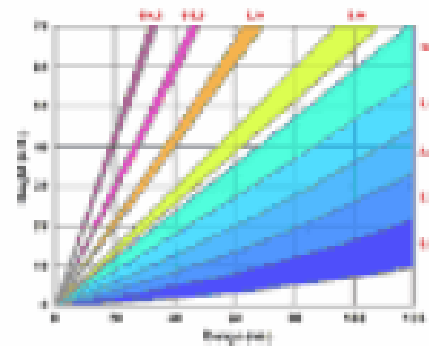

6 min

Fast Scan

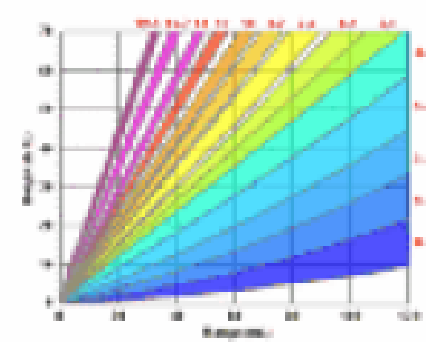

5 min



RADAR BASICS

ECHO TOP

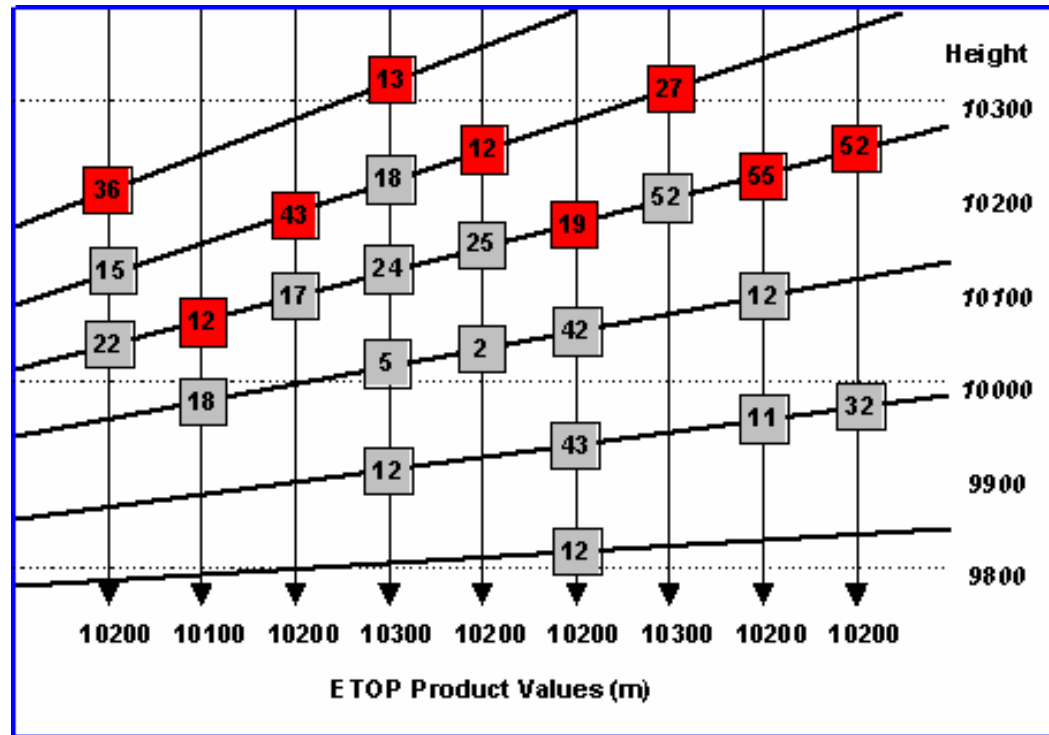

The ECHO TOP product is the height of the highest (in altitude) return in the cell. Either corrected or uncorrected reflectivity may be used to generate the product.

The ETOPS algorithm transverses the volume scan calculating the height of the echoes. The highest in altitude echoes with intensities above the threshold are selected. The resolution is pulse width dependent.



RADAR BASICS

Column Max Intensity

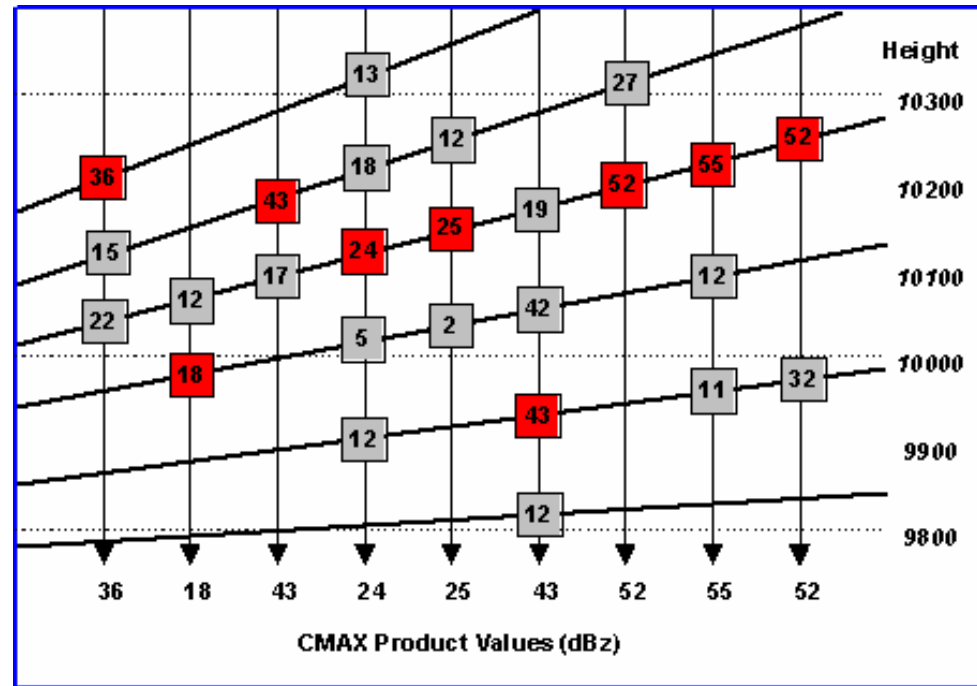

The maximum intensity in a column is an indication of the maximum reflectivity in each cell. A minimum and maximum height may be user-defined and defaults to zero and 30 kilometers.

This allows for generation of layer maximum products by setting these values to the limits of the desired layer, and may be specified up to the maximum range of the volume scan.



RADAR BASICS

Anomalous Propagation (AP) Example

Base Reflectivity

Base Velocity

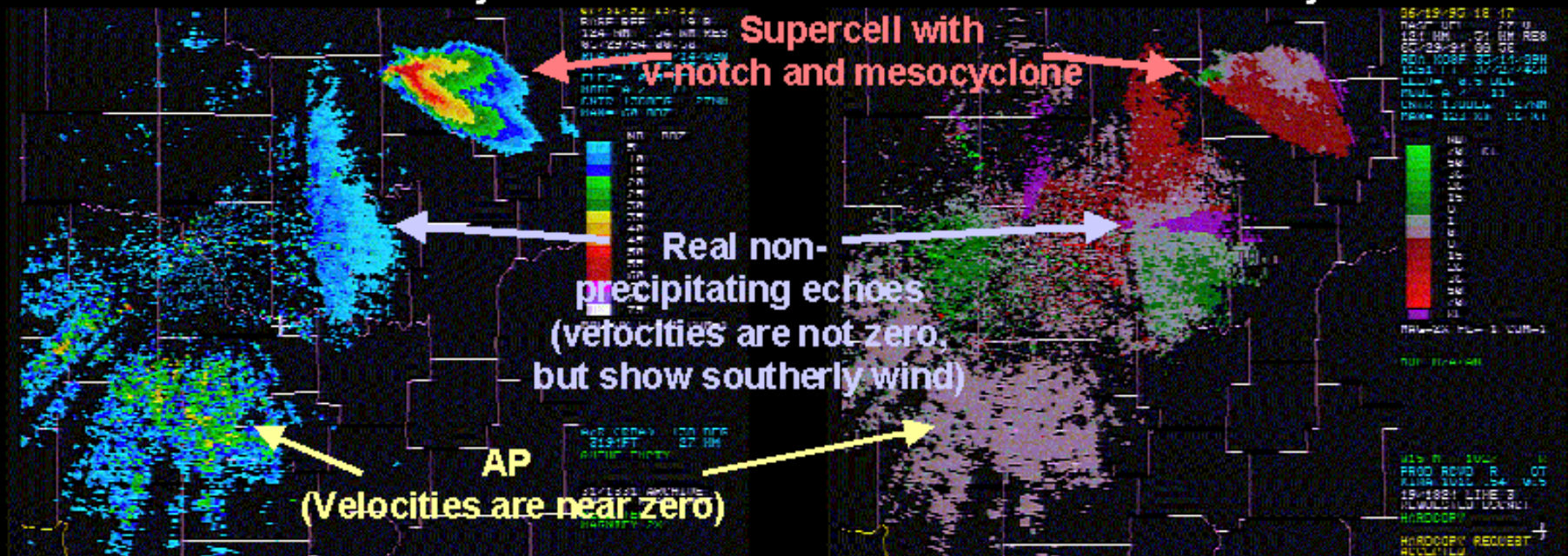

AP is caused by ground returns when the radar beam bends and strikes the earth's surface at a relatively large distance from the radar. *Base* velocities of AP echoes are usually near zero and AP usually only appears on the lowest tilts.

Copyright 2000 Oklahoma Climatological Survey. Portions from the National Weather Service.



RADAR BASICS

Radar Beam Broadening and Comparing Two Radars

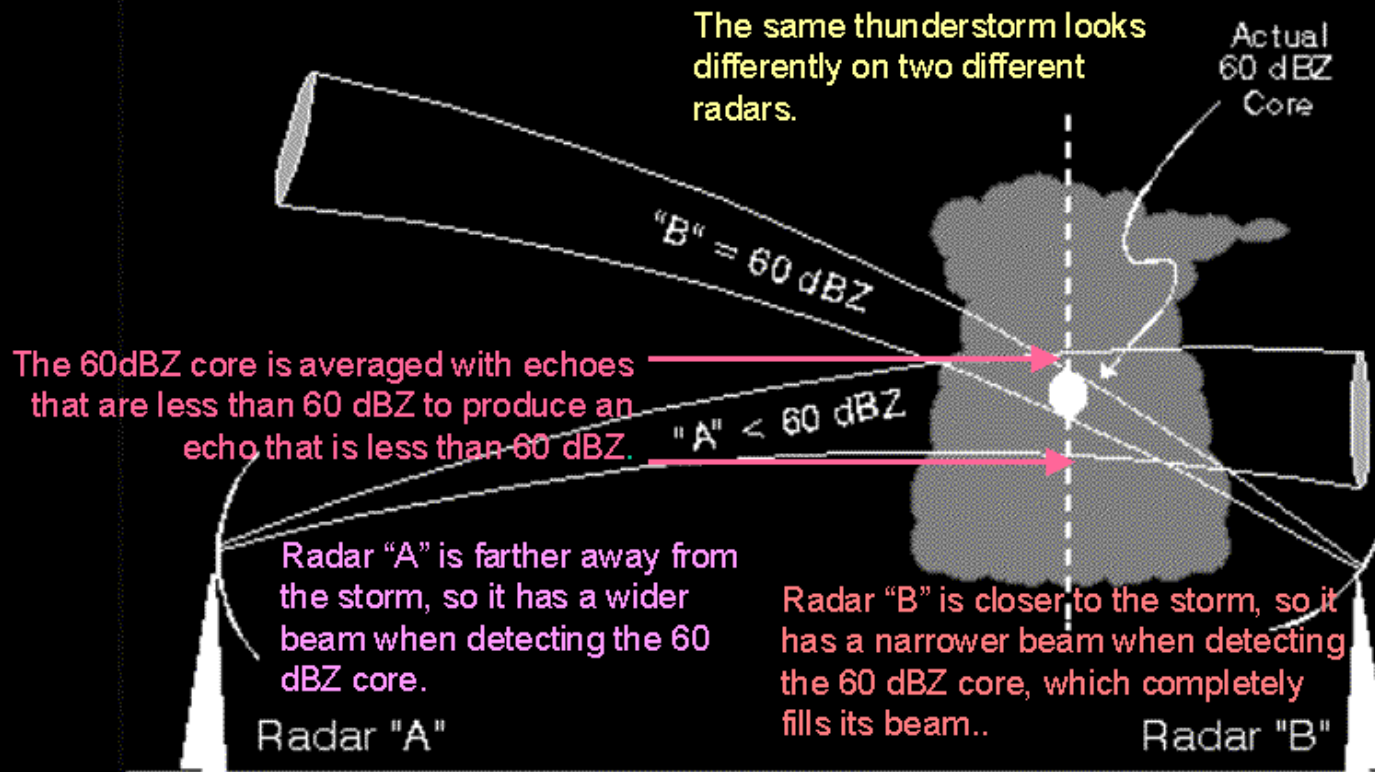

While it is often a good practice to check signatures between multiple radars, broadening of the radar beam with increasing distance from the radar causes storms at far ranges to appear to be weaker than they really are.

Copyright 2000 Oklahoma Climatological Survey. Portions from the National Weather Service/Operational Support Facility.



RADAR BASICS

THE RADAR EQUATION



RADAR BASICS

MONOSTATIC RADAR

The most common radar system configuration, with the radar receiver at the same location as the radar transmitter. In such a system, surfaces of constant range are spheres centered at the radar site, and only the radial component of target velocity causes a Doppler frequency shift

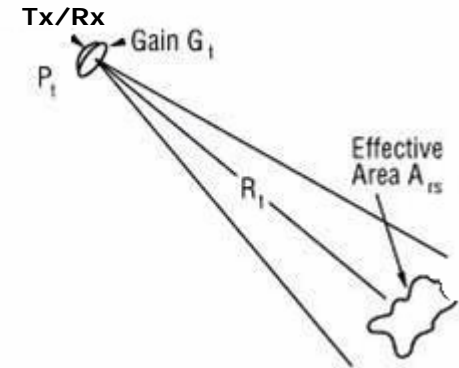

BISTATIC RADAR

A radar system configuration with the receiver located at a site different from the transmitter. In such a system, surfaces of constant range are ellipsoids with the transmitter and receiver sites as foci, and the component of target velocity that induces a Doppler frequency shift is the component normal to the ellipsoids.

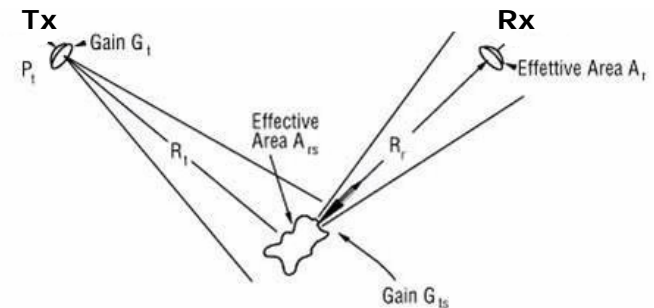



RADAR BASICS

AN EXAMPLE OF A BISTATIC RADAR

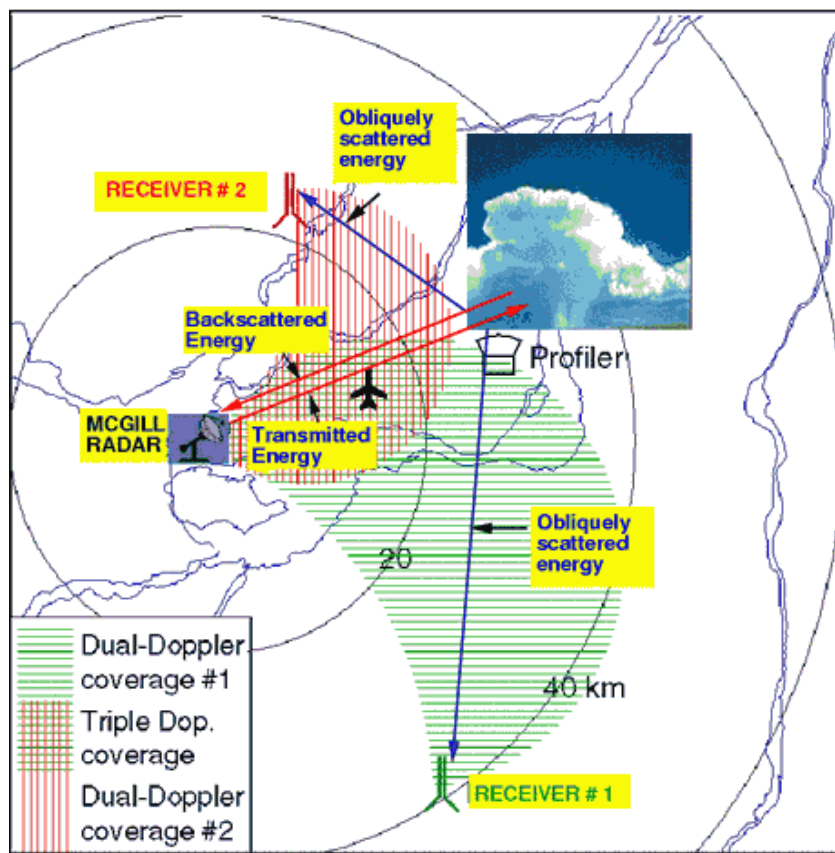



RADAR BASICS

The bistatic receiver concept for radar meteorology was developed by Joshua Wurman while at the National Center for Atmospheric Research.

In this system, a single traditional monostatic weather radar transmits a narrow beam and receives backscattered radiation while one or more passive bistatic receivers receive obliquely scattered radiation.

Because of the multiplicity of view angles, several components of the wind can hence be measured simultaneously. This allows the possibility of directly measuring 3-D winds with a single radar system.

As part of a collaborative effort between the University of Oklahoma, NCAR personnel, and McGill, we operate two bistatic receivers, one installed 40 km to the south-east of the radar and a second one set-up 23 km to the north-east.

Both these receivers are tuned to receive obliquely scattered radiation from the S-band system over an angle of about 70° . This configuration allows multiple-Doppler coverage of the Greater Montreal, including Dorval airport.

The combination of the main radar system and the bistatic receivers is used to support our retrieval work, both as a verification of single radar wind retrievals as well as an additional constraint for thermodynamic retrieval.

Furthermore, the excellent coverage over the airport could improve the detection of severe weather threatening airliners like downbursts.



RADAR BASICS

POWER FLUX DENSITY INCIDENT ON THE TARGET

Consider a radar system illuminating a distant target, as depicted in the following figure. The target is assumed to be far enough away to permit the incident wave to be considered a plane wave. The target is also assumed to be small enough to constitute in effect as a point target. The incident wave is assumed to be linearly polarized.

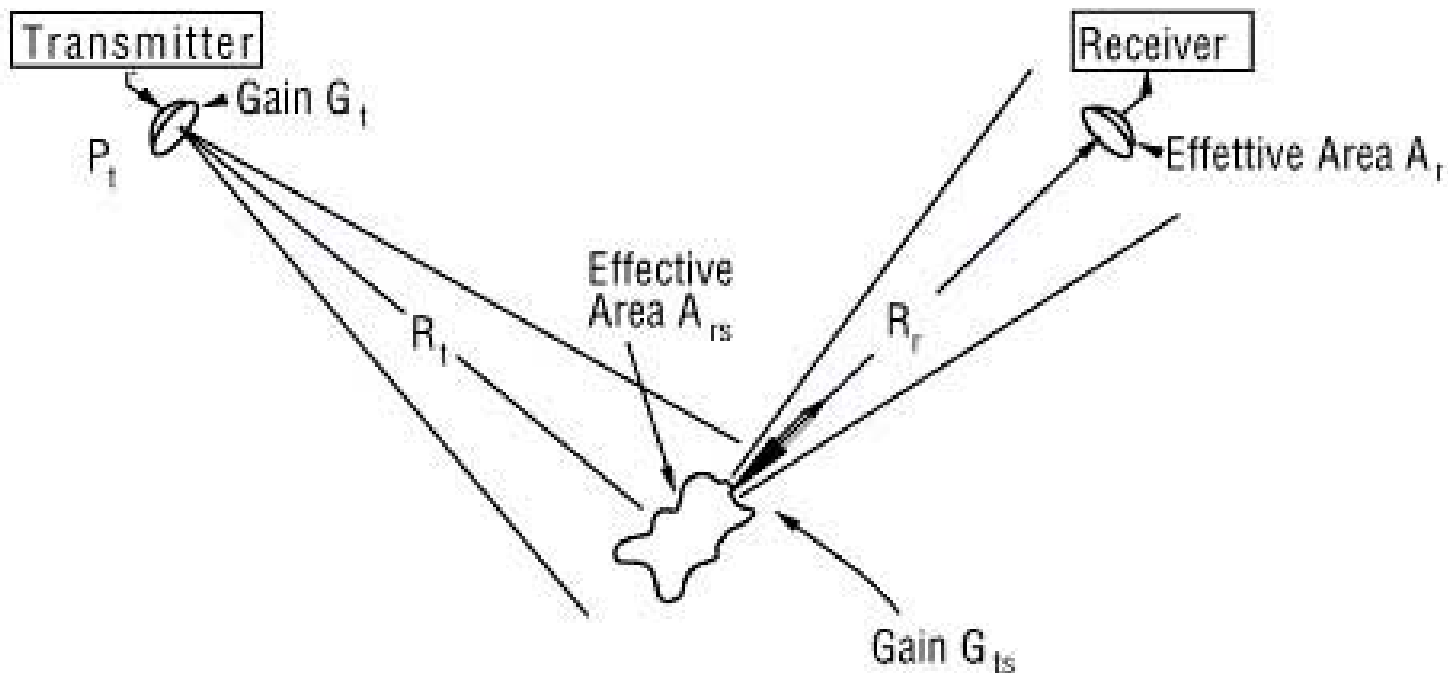



RADAR BASICS

The fundamental relation between the characteristics of the radar, the target, and the received signal is called the radar equation.

The geometry of scattering from an isolated radar target (scatterer) is shown in the figure, along with the parameters that are involved in the radar equation.

When a power P_t is transmitted by an antenna with gain G_t , the power per unit solid angle in the direction of the scatterer is $P_t G_t$, where the value of G_t in that direction is used.

At the scatterer,

$$S_s = (P_t G_t) \left(\frac{1}{4\pi R^2} \right)$$

where S_s is the power density at the scatterer. The effective gain G_t of the radar transmitting antenna is defined as the ratio of the actual power flux density incident on the target, to the power flux density that would result if the lossless, omnidirectional antenna were used.

The spreading loss $\frac{1}{4\pi R^2}$ is the reduction in power density associated with spreading of the power over a sphere of radius R surrounding the antenna.



RADAR BASICS

To obtain the total power intercepted by the scatterer, the power density must be multiplied by the effective receiving area of the scatterer:

$$P_{rs} = S A_{rs}$$

Note that the effective area A_{rs} is not the actual area of the incident beam intercepted by the scatterer, but rather is the effective area;

i.e., it is that area of the incident beam from which all power would be removed if one assumed that the power going through all the rest of the beam continued uninterrupted.

The actual value of A_{rs} depends on the effectiveness of the scatterer as a receiving antenna.

Some of the power received by the scatterer is absorbed in losses in the scatterer unless it is a perfect conductor or a perfect isolator; the rest is reradiated in various directions. The fraction absorbed is f_a , so the fraction reradiated is $1 - f_a$, and the total reradiated power is

$$P_{rs} = P_{rs}(1 - f_a)$$



RADAR BASICS

The conduction and displacement currents that flow in the scatterer result in reradiation that has a pattern (like an antenna pattern). Note that the effective receiving area of the scatterer is a function of its orientation relative to the incoming beam, so that A_{rs} in the equation above is understood to apply only for the direction of the incoming beam.

The reradiation pattern may not be the same as the pattern of A_{rs} , and the gain in the direction of the receiver is the relevant value in the reradiation pattern.

Thus,

$$S_r = P_{ts} G_{ts} \frac{1}{4\pi R_r^2}$$

where P_{ts} is the total reradiated power, G_{ts} is the gain of the scatterer in the direction of the receiver, and

$$\frac{1}{4\pi R_r^2}$$

is the spreading factor for the reradiation.



RADAR BASICS

Note that a major difference between a communication link and radar scattering is that the communication link has only one spreading factor, whereas the radar has two.

Thus, if $R_r = R_t$, the total distance is $2R_t$;

for a communication link with this distance, the spreading factor is only:

$$1/4 \left(\frac{1}{4\pi R_t^2} \right)$$

whereas for the radar it is:

$$\left(\frac{1}{4\pi} \right)^2 \left(\frac{1}{R_t} \right)^4$$

Hence, the spreading loss for a radar is much greater than for a communication link with the same total path length.



RADAR BASICS

The power entering the receiver is (5) $P_r = S A_r$.

where the area A_r is the effective aperture of the receiving antenna, not its actual area.

Not only is this a function of direction, but it is also a function of the load impedance the receiver provides to the antenna;

for example, P_r would have to be zero if the load were a short circuit or an open circuit.

The factors in the eq. 1 through the eq. 5 may be combined to obtain

$$\begin{aligned}
 (6) \\
 P_r &= (P/G) \left(\frac{1}{4\pi R_s^2} \right) A_r (1 - f_{sc}) G_{ts} \left(\frac{1}{4\pi R_r^2} \right) A_r \\
 &= \left(\frac{P/G A_r}{(4\pi)^2 R_s^2 R_r^2} \right) [A_r (1 - f_{sc}) G_{ts}]
 \end{aligned}$$

The factors associated with the scatterer are combined in the square brackets.



RADAR BASICS

These factors are difficult to measure individually, and their relative contributions are uninteresting to one wishing to know the size of the received radar signal. Hence they are normally combined into one factor, the radar scattering cross section:

(7)

$$\sigma = A_e (1 - f_d) G_{ts}$$

The radar cross-section is a measure of the nature and size of the target. It characterizes the target in a way that is especially useful for calculating the echo power to be expected from the target.

The cross-section σ is a function of the directions of the incident wave and the wave toward the receiver, as well as that of the scatterer shape and dielectric properties.

The final form of the radar equation is obtained by rewriting the eq. 6 using the definition of the eq. 7: (8)

$$P_r = \frac{P_t G_t A_e}{(4\pi)^2 R_t^2 R_r^2} \sigma$$



RADAR BASICS

The most common situation is that for which receiving and transmitting locations are the same, so that the transmitter and receiver distances are the same.

Almost as common is the use of the same antenna for transmitting and receiving, so the gains and effective apertures are the same, that is:

$$\begin{aligned}R_t &= R_r = R \\G_t &= G_r = G \\A_t &= A_r = A\end{aligned}$$

Since the effective area of an antenna is related to its gain by:
(9)

$$A = \frac{\lambda^2 G}{4\pi}$$



RADAR BASICS

we may rewrite the radar equation (eq. 8) as (10)

$$P_r = \frac{P_t G^2 \lambda^2 \sigma}{(4\pi)^3 R^4} = \frac{P_t A^2 \sigma}{4\pi \lambda^2 R^4}$$

where two forms are given, one in terms of the antenna gain and the other in terms of the antenna area.

The radar equations (eq. 8 and eq. 10) are general equations for both point and area targets.

That is, the scattering cross-section σ is not defined in terms of any characteristic of a target type, but rather is the scattering cross-section of a particular target.

The form given in the equation 10 is for the so-called monostatic radar, and that in eq. 8 is for bistatic radar, although it also applies for monostatic radar when the conditions for R , G , A given above are satisfied.



RADAR BASICS

$$P_r = \frac{P_t G^2 \theta^2 H \pi^3 K^2 L}{1024 (\ln 2) \lambda^2} \times \frac{Z}{R^2}$$

Below is the list of variables, what they are, and how they are measured.

- Pr:** Average power returned to the radar from a target. The radar sends up to 25 pulses and then measures the average power that is received in those returns. The radar uses multiple pulses since the power returned by a meteorological target varies from pulse to pulse. This is an unknown value of the radar, but it is one that is directly calculated.
- Pt:** Peak power transmitted by the radar. This is a known value of the radar. It is important to know because the average power returned is directly related to the transmitted power.
- G:** Antenna gain of the radar. This is a known value of the radar. This is a measure of the antenna's ability to focus outgoing energy into the beam. The power received from a given target is directly related to the square of the antenna gain.
- θ :** Angular beam width of the radar. This is a known value of the radar. Through the Probert-Jones equation it can be learned that the return power is directly related to the square of the angular beam width. The problem becomes that the assumption of the equation is that precipitation fills the beam for radars with beams wider than two degrees. It is also an invalid assumption for any weather radar at long distances. The lower resolution at great distances is called the aspect ratio problem.



RADAR BASICS

- H:** Pulse Length of the radar. This is a known value of the radar. The power received from a meteorological target is directly related to the pulse length.
- K:** This is a physical constant. This is a known value of the radar. This constant relies on the dielectric constant of water. This is an assumption that has to be made, but also can cause some problems. The dielectric constant of water is near one, meaning it has a good reflectivity. The problem occurs when you have meteorological targets that do not share that reflectivity. Some examples of this are snow and dry hail since their constants are around 0.2.
- L:** This is the loss factor of the radar. This is a value that is calculated to compensate for attenuation by precipitation, atmospheric gases, and receiver detection limitations. The attenuation by precipitation is a function of precipitation intensity and wavelength. For atmospheric gases, it is a function of elevation angle, range, and wavelength. Since all of this accounts for a 2dB loss, all signals are strengthened by 2 dB.
- λ : This is the wavelength of the transmitted energy. This is a known value of the radar. The amount of power returned from a precipitation target is inversely since the short wavelengths are subject to significant attenuation. The longer the wavelength, the less attenuation caused by precipitate.



RADAR BASICS

- Z:** This is the reflectivity factor of the precipitate. This is the value that is solved for mathematically by the radar. The number of drops and the size of the drops affect this value. This value can cause problems because the radar cannot determine the size of the precipitate. The size is important since the reflectivity factor of a precipitation target is determined by raising each drop diameter in the sample volume to the sixth power and then summing all those values together. A $\frac{1}{4}$ " drop reflects the same amount of energy as 64 $\frac{1}{8}$ " drops even though there is 729 times more liquid in the $\frac{1}{8}$ " drops.
- R:** This is the target range of the precipitate. This value can be calculated by measuring the time it takes the signal to return. The range is important since the average power return from a target is inversely related to the square of its range from the radar. The radar has to normalize the power returned to compensate for the range attenuation.



RADAR BASICS

Minimum Detectable Signal



RADAR BASICS

RADAR RECEIVER NOISE IMPLICATIONS

The radar receiver is limited in its ability to detect an echo signal by the noise energy which occupies the same portion of the frequency spectrum as the signal.

The weakest echo signal a radar can detect is referred to as the minimum detectable signal (MDS). The MDS can be difficult to specify because it is a statistical quantity and criterion for declaring a detection may vary with circumstances.

Detection is often based on establishing a threshold level at the radar receiver. If the threshold is too high, then weak signals or echoes may be missed altogether.

On the other hand, if the level is set too low, then it is more likely that noise alone will be mistaken for targets, and false alarms will result. The noise that is present in the radar receiver ultimately limits receiver sensitivity.

The receiver is sensitive to the range of frequencies being transmitted and provides amplification of the returned signal.



RADAR BASICS

In order to provide the greatest range, the receiver must be very sensitive without introducing excessive noise. The ability to discern a received signal from background noise depends on the signal-to-noise ratio (S/N).

The background noise is specified by an average value, called the noise-equivalent-power (NEP). This directly equates the noise to a detected power level so that it may be compared to the return. Using these definitions, the criterion for successful detection of a target is

$P_r > (S/N) \text{ NEP}$, where P_r is the power of the return signal. Since this is a significant quantity in determining radar system performance, it is given a unique designation, S_{min} , and is called the *Minimum Signal for Detection*.

$$S_{\text{min}} = (S/N) \text{ NEP}$$

Since S_{min} , expressed in Watts, is usually a small number, it has proven useful to define the decibel equivalent, MDS, which stands for *Minimum Discernible Signal*.

$$\text{MDS} = 10 \text{ Log } (S_{\text{min}}/1 \text{ mW})$$



MDS and RANGE

RADAR BASICS

There is thus a bottom threshold on the ability to detect echoes.

For most of the radars, the MDS is about 15 dBZ for a signal at 100 km. This means that a storm weaker than 15 dBZ at 100 km, will not be detected by the radar.

If a storm is closer than 100km to the radar with intensity below 15 dBZ, it might be detected.

If the storm is farther than 100km, the threshold increases to more than 15 dBZ. The reason for this, is the expansion of the radar beam with range, which reduces the incident power on hydrometeors, while the extended distance back to the radar weakens the signal even more.

A range correction term is build into the radar equation, but the minimum threshold of the receiver ultimately determines whether the storm will be observed or not.

The implication for the user, is to be cognitive of the fact that weak storms are often not detected at long ranges. This has impact on the observation of general rain at long range from the radar. Often it does rain lightly at long range, but it is not detected by the radar.



RADAR BASICS

THE Z-R CONVERSION



RADAR BASICS

DERIVING RAINFALL FROM REFLECTIVITY

Rainfall rates (R) are directly related to the drop size distribution of precipitation, based on the diameter cubed.

Reflectivity (Z) is directly related to the drop size distribution of precipitation, based on the diameter to the sixth power.

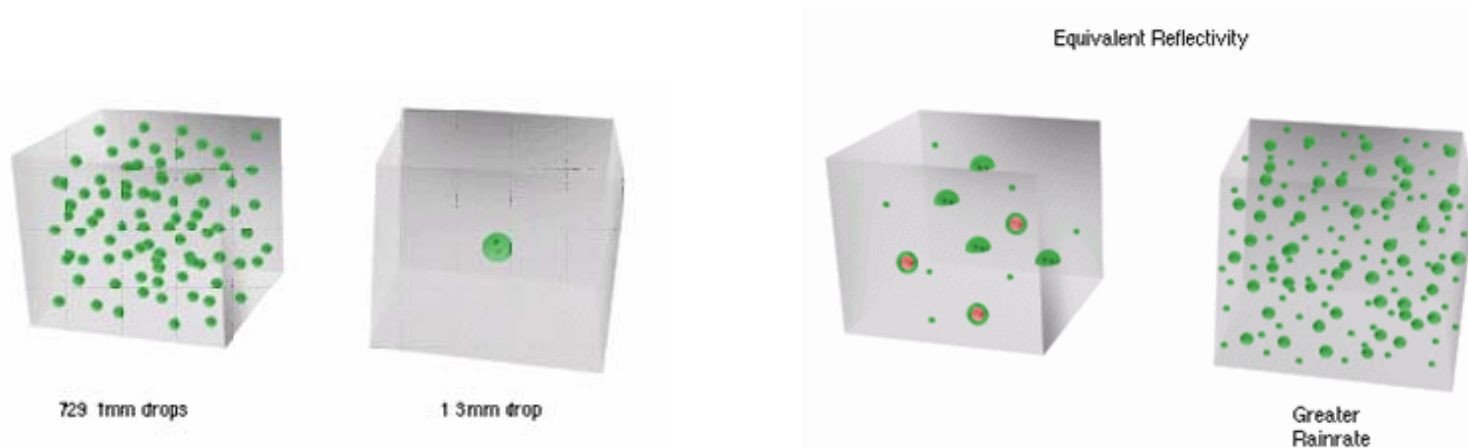

If the drop size distribution were known, the relationship between Z and R could be calculated. It is not known, so no unique relationship between Z and R can be defined. Instead empirical relationships have been developed.



RADAR BASICS

DROP-SIZE DISTRIBUTION

The frequency distribution of drop sizes (diameters, volumes) that is characteristic of a given cloud or of a given fall of rain.

Most natural clouds have unimodal (single maximum) distributions, but occasionally bimodal distributions are observed.

In convective clouds, the drop-size distribution is found to change with time and to vary systematically with height, the modal size increasing and the number decreasing with height.

For many purposes a useful single parameter representing a given distribution is the volume median diameter, that is, that diameter for which the total volume of all drops having greater diameters is just equal to the total volume of all drops having smaller diameters.

The drop-size distribution is one of the primary factors involved in determining the radar reflectivity of any fall of precipitation, or of a cloud mass.



DROP SPECTRA

RADAR BASICS For a raindrop spectra represented by a normalized gamma function

$$N(D) = N_w f(\mu) \left(\frac{D}{D_0} \right)^\mu \exp\left(-\frac{(3.67 + \mu)D}{D_0} \right)$$

$$f(\mu) = \frac{6}{(3.67)^4} \frac{(3.67 + \mu)^{\mu+4}}{\Gamma(\mu + 4)}$$

D_0 = Median equivolumetric drop size

N_w = Normalised concentration

μ = width of spectrum

For each Z_{dr} calculate Z for $R = 1 \text{ mm/h}$
 $\text{dBZ} (1 \text{ mm/hr}) = f(Z_{dr})$

Increase N_w , both R and Z scale with N_w ,
 $\text{dBR} = \text{dBZ}(\text{obs}) - f(Z_{dr})$

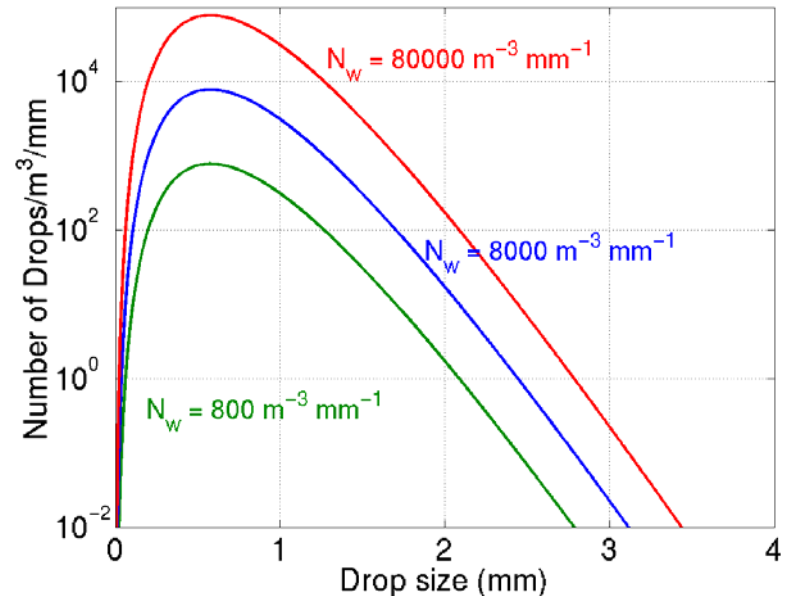

bigger drops become more oblate

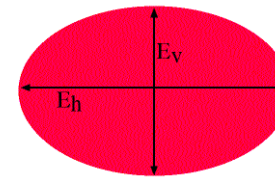

so $\sigma_h > \sigma_v$



RADAR BASICS

Thus, the rainfall rate (in depth per time) is given by

$$R = \frac{\pi}{6} \int_0^{\infty} u(D) D^3 n(D) dD$$

For the Marshall-Palmer distribution this equation is

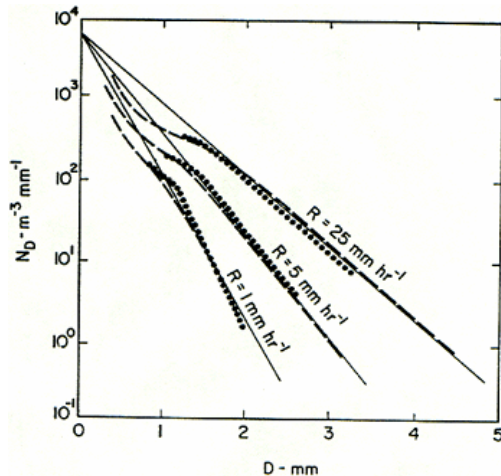

$$n(D) = N_0 \exp(-\Lambda D)$$

$$R = \frac{\pi}{6} N_0 \int_0^{\infty} u(D) D^3 \exp(-\Lambda D) dD$$



RADAR BASICS

The drop size has an important effect on the attenuation and reflectivity of the weather. In addition, depending on the precipitation rate, there can be some degree of confidence that certain volumes of drop size will be found in a cloud.

When this is known, the reflectivity of these drop types can be estimated and the comparative reflectivity by rainfall rate estimated. The following table helps to illustrate this.

The expected percentage of drops of specific sizes over precipitation rates is shown below.

Drop Diameter (D - cm)	Precipitation Rate (mm/hr)			
	0.25	1.25	2.5	12.5
	Percentage of given volume containing drops of diameter D			
0.05	28.0	10.9	7.3	2.6
0.10	50.1	37.1	27.8	11.5
0.15	18.2	31.3	32.8	24.5
0.20	3.0	13.5	19.0	25.4
0.25	0.7	4.9	7.9	17.3
0.30	-	1.5	3.3	10.1
0.35	-	0.6	1.1	4.3



RADAR BASICS

TYPICAL CLOUD DROP SPECTRA

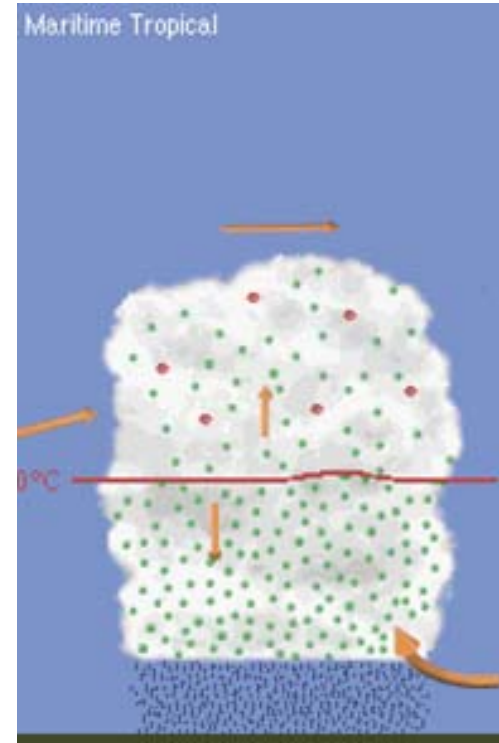
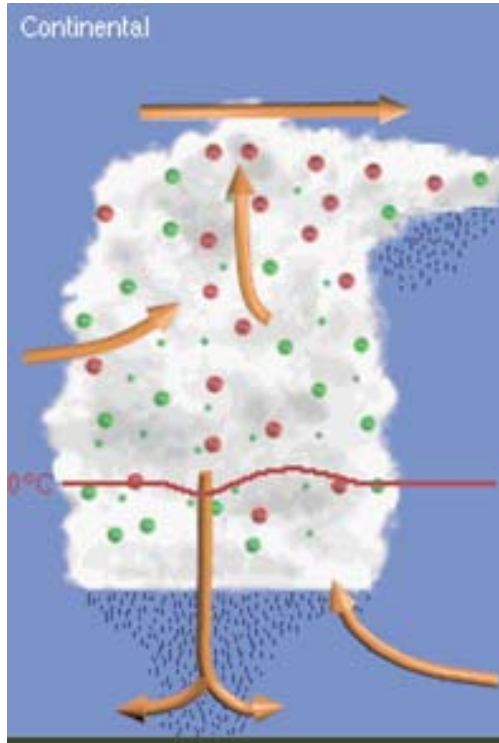



RADAR BASICS

RADAR x RAINGAUGE

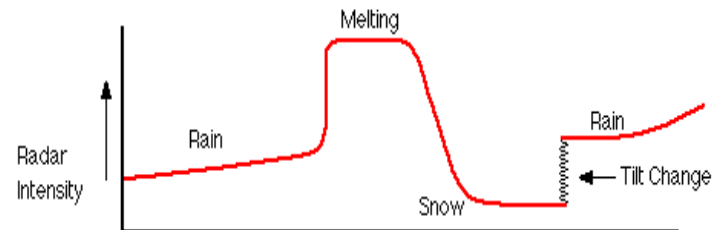
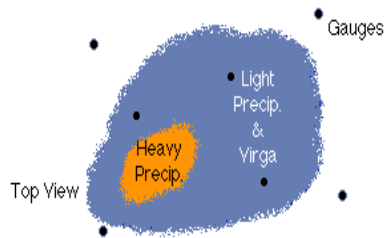
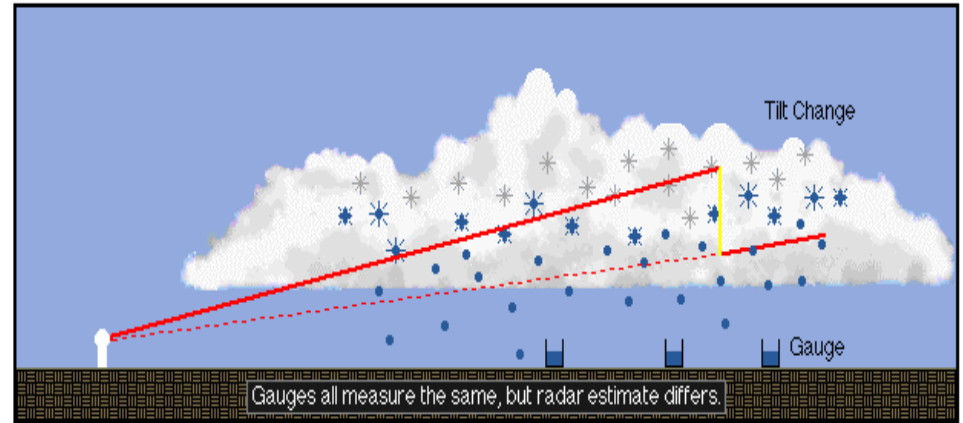
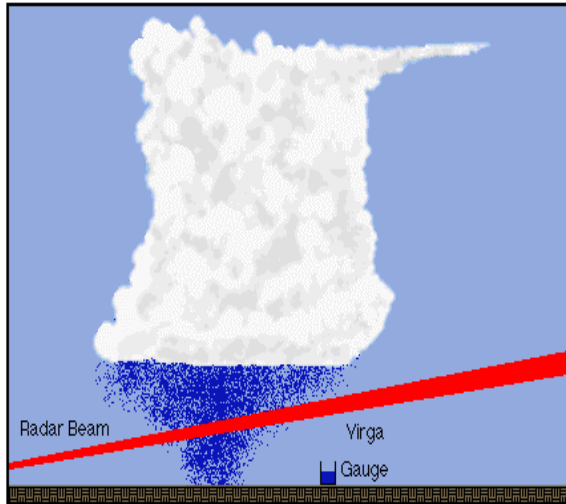



RADAR BASICS

RADAR REFLECTIVITY

In general, a measure of the efficiency of a radar target in intercepting and returning radio energy.

It depends upon the size, shape, aspect, and dielectric properties of the target. It includes not only the effects of reflection but also scattering and diffraction.

In particular, the radar reflectivity of a meteorological target depends upon such factors as:

- the number of hydrometeors per unit volume;
- the sizes of the hydrometeors;
- the physical state of the hydrometeors (ice or water);
- the shape or shapes of the individual elements of the group; and
- if asymmetrical, their aspect with respect to the radar. The radar reflectivity has dimensions of area per unit volume (e.g., cm^2m^3 , or, more commonly, cm^1 or m^1) and is defined by

$$\eta = \sum_i N_i \sigma_i,$$

where N_i is the number of hydrometeors per unit volume with backscattering cross section σ_i and the summation is over all the hydrometeors in a unit volume.



RADAR BASICS

For spherical hydrometeors small enough compared with the wavelength for the Rayleigh scattering approximation to be valid, the radar cross section is related to particle size by

$$\sigma = \frac{\pi^5 |K|^2 D^6}{\lambda^4}, \quad K = \frac{m^2 - 1}{m^2 + 2},$$

where λ is the wavelength, D the diameter of the hydrometeor, and K a dielectric factor defined by

$$\eta = \frac{\pi^5}{\lambda^4} |K|^2 \sum_{i=1}^n D_i^6 \quad Z = \sum_{i=1}^n D_i^6$$

where m is the complex index of refraction of the hydrometeor.

For radar bands L to X water has $|K|^2 = 0.93$ and for ice $|K|^2 = 0.2$



RADAR BASICS

The intensity of the return signal (**radar echo**) received by the radar depends not only on the intensity of the rain, but also on the distance of the rain from the radar, and on the sensitivity of the radar antenna and electronics. Rain that is further away returns a weaker signal than rain close by.

The radar software automatically computes a range-corrected and equipment-calibrated measure of reflectivity, which is given the symbol **Z**. But **Z** can vary from extremely large values for heavy rain, to very small values for mist. To make this wide range of **Z** accessible and viewable on computer screens, the software first takes the logarithm of **Z**, which is expressed in units of decibels (**dB**). Hence, the numbers that are usually displayed on reflectivity radar images are in units of **dBZ**.

Larger values of dBZ correspond to heavier rain from more intense thunderstorms, while small values correspond to light rain from shallow clouds, or returns from bugs. Rainfall rate (**RR**) is defined as the rate of increase of depth of water in a reengage, measured in mm/hour.

An approximate relationship between **dBZ**, **RR**, and descriptive intensity is given in the following figure.

For example, a radar reflectivity of 40 dBZ corresponds to an approximate rainfall rate of $RR = 10$ mm/h, which is a moderate rainfall rate.



RADAR BASICS

Rainfall is most often measured using a relationship between the

REFLECTIVITY FACTOR (Z in mm⁶/m⁻³)

and its

PRECIPITATION INTENSITY (R in mm / hr⁻¹)

Pre-defined reflectivity tables are held at a station and used as the basis for the initial interpretation and calculation.

The rainfall rate R can be empirically related to the reflectivity factor Z by the expression:

$$Z = AR^b$$

where A and b are constants and R is the rainfall rate in mm/hr.

The reflectivity factor Z is dependent on the size and number of rain drops per unit volume of space and has the units of mm⁶/m⁻³.

Many researchers have produced a large variety of values A and b.

The value of A and b will be specific to each radar site configuration.

A number of ambiguities are known and possible, depending on the radar configuration and the particular meteorological situation.



RADAR BASICS

ZR relationships

Typical expressions for types of precipitation

stratiform rain	$Z = 200R^{1.6}$
orographic rain	$Z = 31R^{1.71}$
thunder storms	$Z = 286R^{1.37}$
snow	$Z = 2000R^2$

In the absence of further information it is generally acceptance, in mid-latitude temperature climates, to use a default value of $Z = 200R^{1.6}$.

Usually Z is specified in a logarithmic scale where $ZdB = 10 \log Z$.



RADAR BASICS

ZR relationships

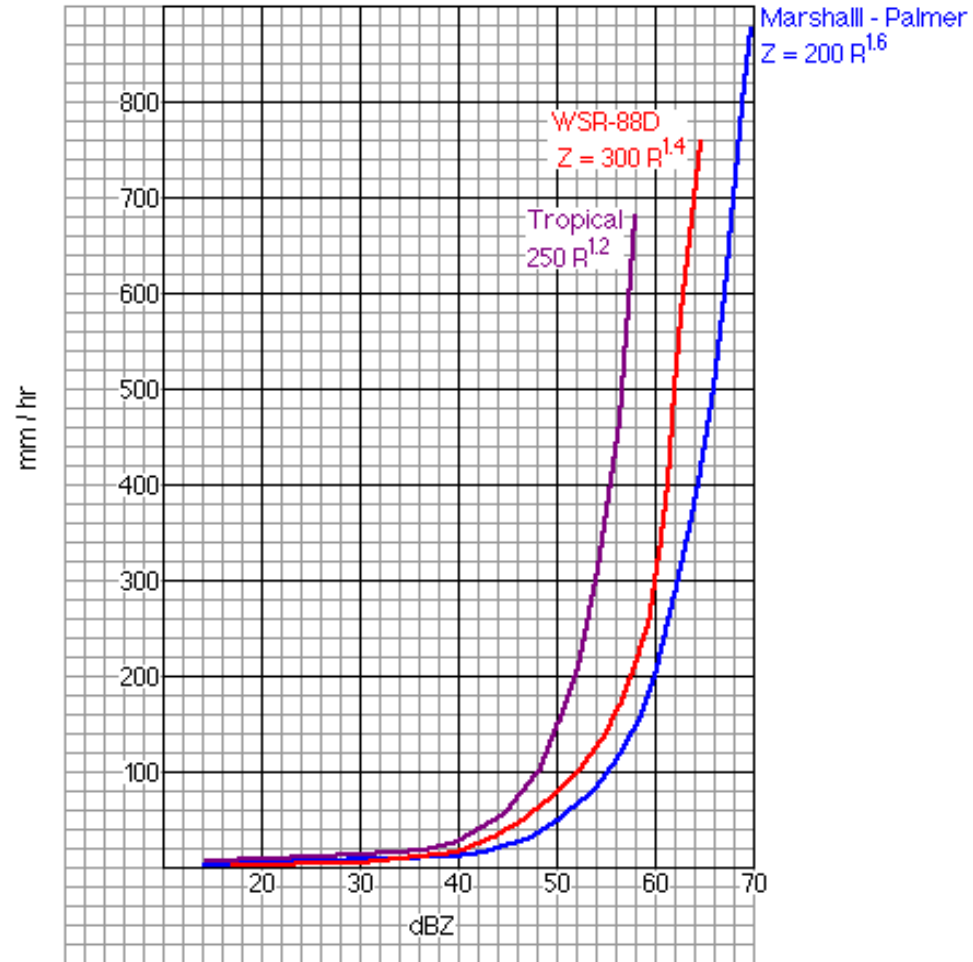



RADAR BASICS

RAINFALL CATEGORY

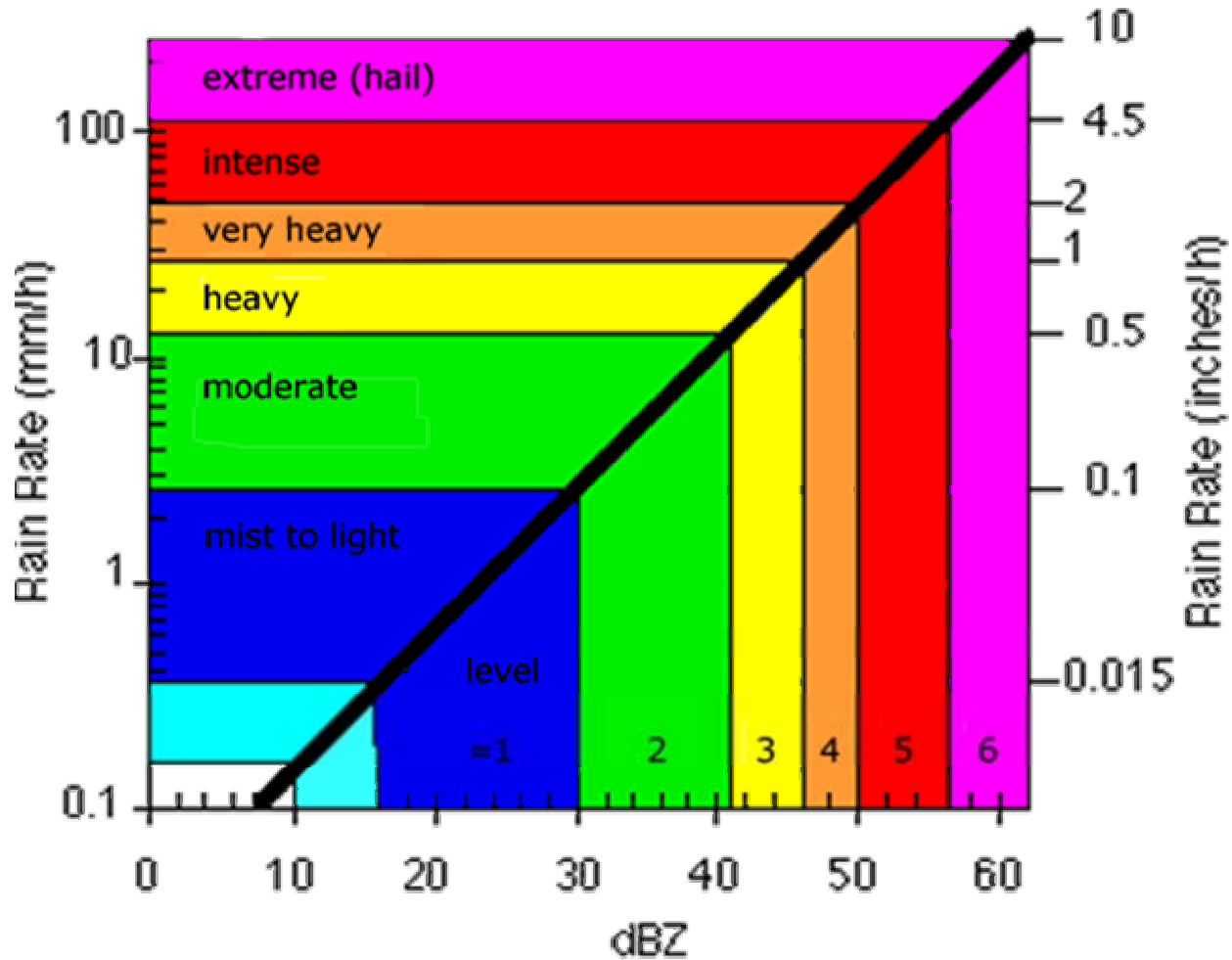



RADAR BASICS

ATTENUATION



RADAR BASICS

ATTENUATION

Attenuation is the weakening of a radar beam as it moves downstream due to some of the energy being lost to scattering and absorption.

The further a radar beam moves downstream the more dust, hydrometeors, etc the radar beam will have to pass through. Because of attenuation, storms close to the radar are better sampled than storms far from the radar site.

Beam spreading and attenuation both combine to produce a much poorer sampling of storms far from the radar.

Attenuation is higher when the radar beam has the flow through a large number of hydrometeors.

Storms and precipitation close to the radar degrade the radar energy before it reaches storms further from the radar.

Smaller wavelength radar beams attenuate more rapidly than long wavelength radar.

Because of this C-band have a shorter range of high clarity compared to the S-band.



RADAR BASICS

Integrating the left-hand side gives

$$P_r = P_0 e^{-2 \int_0^r \kappa dr}$$

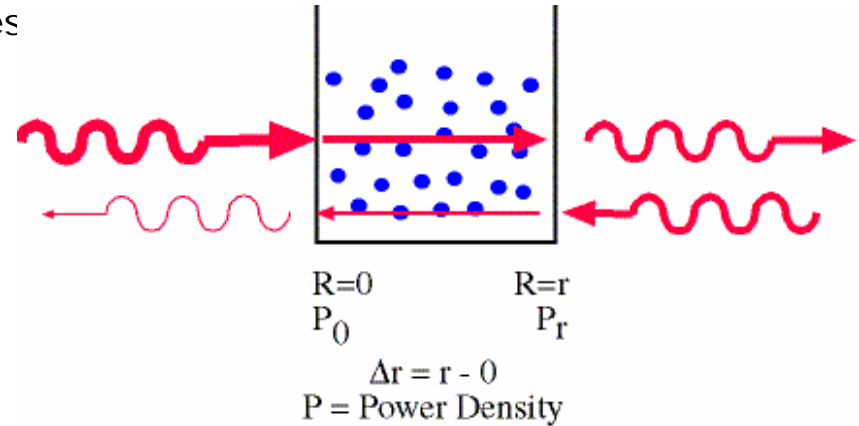

where the exponential term is the **attenuation factor** which we will define as:

$$\kappa = e^{-2 \int_0^r \kappa dr}$$

Substituting into the radar equation gives:

$$P_r = \frac{\pi^3 P_t G^2 \theta^2 h |k_w|^2 \kappa Z_e}{1024 \ln(2) \lambda^2 r^2}$$



RADAR BASICS

RAIN ATTENUATION

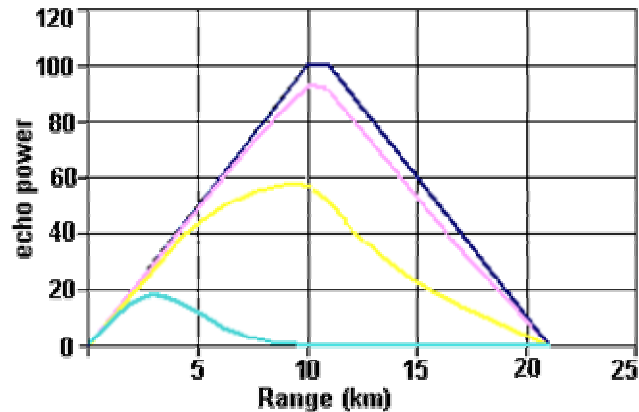

This graphic shows the effect that the rain attenuation has a different value at different wavelengths.

The top (blue) curve shows the unattenuated weather, for a cylindrical storm with 20 km in diameter and rainfall intensity rising to 100 mm/hr in the centre.

The next (mauve) curve shows the returns as seen by an S band radar.

The next two curves (yellow and light blue) show the outputs from a C band and a X band radar. All the results have been normalised.

It is obvious that X band suffers from attenuation and cannot see far into a severe storm, while S band has little attenuation.

C band offers a good compromise. For these reasons, X band weather radars are only used for short ranges, S band radars are used in the tropics because they can see beyond a severe storm, and C band is favoured in temperate latitudes, having good sensitivity and range.



RADAR BASICS

RADIAL VELOCITY



RADAR BASICS

THE DOPPLER EFFECT

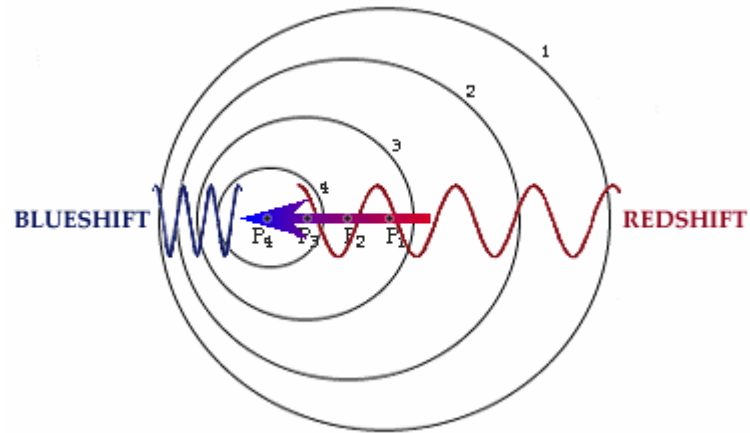

Dopper Velocity Interpretation

Objects moving away decrease waves' frequency.

Objects moving toward antenna increase waves' frequency.



THE DOPPLER RADAR

RADAR BASICS

Doppler radars can measure the component of the velocity of targets toward or away from the radar. This component is called the "radial velocity".

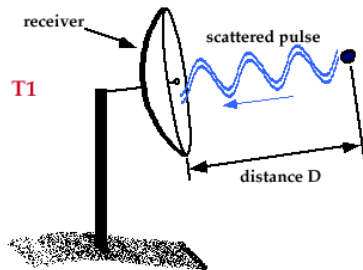

At time T1 a pulse is sent towards a target and it returns a target distance "D".

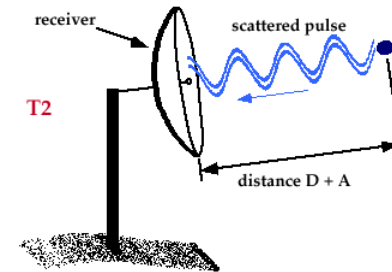

At time T2, another pulse is sent towards the same target and returns a target distance "D+A".

The distance to target has changed from times T1 to T2, resulting in a phase shift between the two return signals, which Doppler radars are capable of measuring. By knowing the phase shift, the wavelength and the time interval from T1 to T2, the velocity the target has moved toward or away from the radar can be computed.

If the target is moving sideways so that its distance relative to the radar does not change, the radar will record zero radial velocity for that target.



RADAR BASICS

PPI display of the Radial Velocity

Operational measurement of Doppler weather radars consists of several PPI measurements (measurements with constant elevation angle and varying azimuth) at different elevation angles.

The most simple visualization of these "volume" data is the projection of single PPI into the horizontal plane.

The value in each pixel is then expressed by certain color from a color or gray scale.

The distance from radar r and elevation angle of the corresponding PPI level α give the altitude of displayed target $z = r \sin \alpha$.

Such visualization of a scalar field (as radar reflectivity or rain rate) is clear and intuitive.

The same is not true for a vector field such as velocity and, thus, during PPI interpretation, we have to remember that Doppler radar does not measure velocity vector but only magnitude of its radial component.



RADAR BASICS

A Doppler" radar has the capability of measuring some information about winds (on top of the usual echo strength all radars measure) by using the Doppler effect.

Although many radars are "Doppler", this additional information is almost never shown to the public because it can be difficult to interpret even for experienced meteorologists. Those images are almost never shown to the public because it can be difficult to interpret even for experienced meteorologists.

The most common wind information measured by a Doppler radar is the radial velocity, which is the component of the wind going in the direction of the radar (either towards or away).

If we take the example of a constant wind from the north, strong approaching velocities will be observed when the radar looks north, strong receding velocities when the radar looks south, and no velocity when the radar looks east or west.

This information can then be displayed, generally using progressively colder colors (for example blue) for increasingly strong approaching velocities and progressively warmer colors (for example red) for increasingly strong receding velocities.

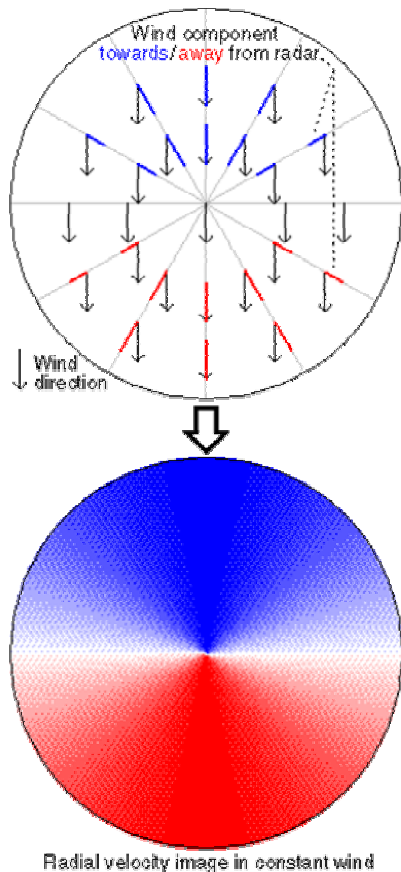

Zero Isodops – zones of zero velocities



RADAR BASICS

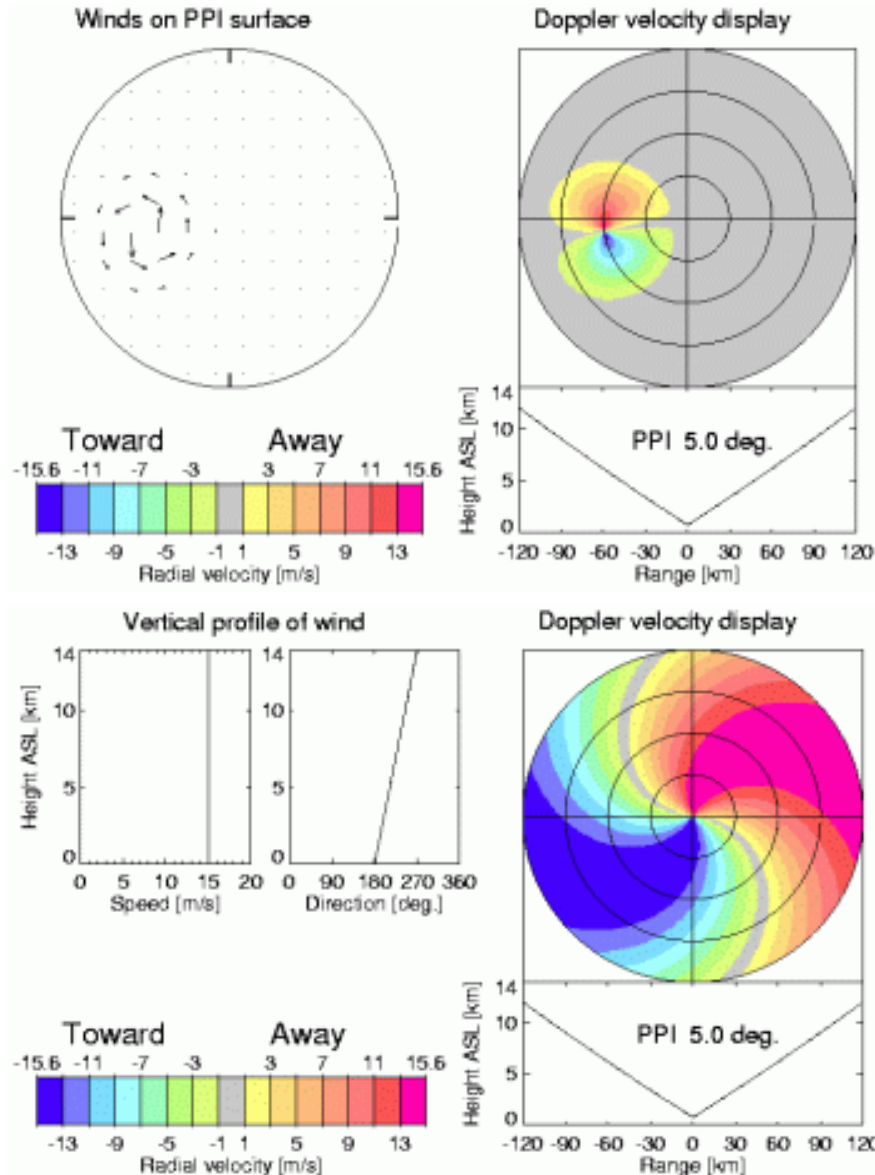

Doppler velocity fields simulation

Simulations of PPI visualization of Doppler velocities for different observed wind fields were created to provide help with operational interpretation of Doppler data in the future.

Simulations were done not only for horizontally uniform wind field but also for more complex fields, e.g. divergence, convergence or cyclonic and anticyclonic rotation.

Simulation of aliased velocity and frontal discontinuity wind field can also be created.

Examples of these simulations are shown in this figure.



RADAR BASICS

Radial Velocity vs Actual Velocity

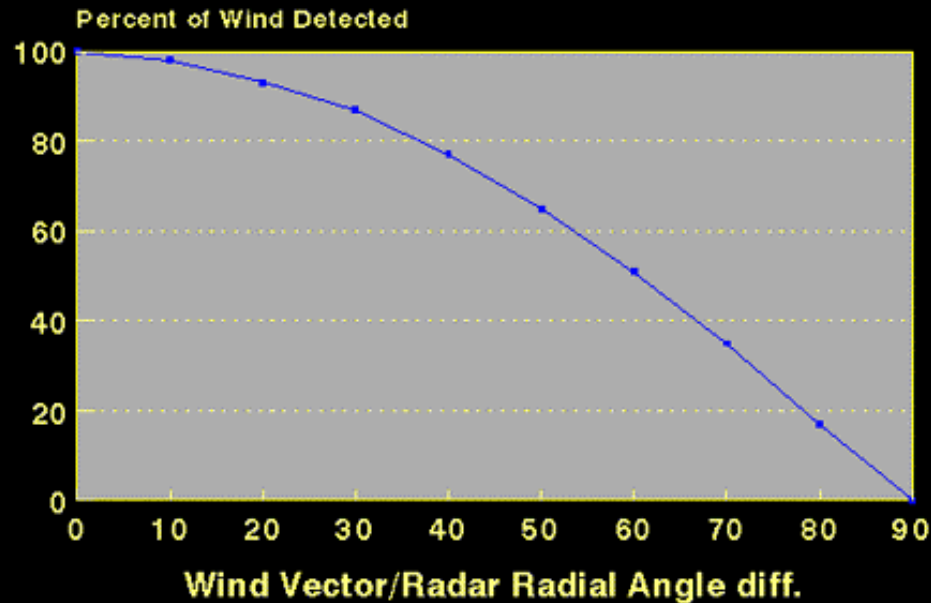

The amount of the wind speed that a radar detects depends on the angle between the wind and the direction the antenna points.

Actual Wind	Antenna Direction (Radial)	Difference	Amount of Wind Detected
S (180°) @ 30 kts	S (180°)	0°	100 % (30 kts)
S (180°) @ 30 kts	SSW (203°)	23°	95 % (28.5 kts)
S (180°) @ 30 kts	SW (225°)	45°	70 % (21 kts)
S (180°) @ 30 kts	WSW (248°)	68°	38 % (11.4 kts)
S (180°) @ 30 kts	W (270°)	90°	0 % (0 kts)

Copyright 2000 Oklahoma Climatological Survey. Portions from the National Weather Service/Operational Support Facility.



RADAR BASICS

Radial velocity images are usually more complicated than in this example because:

- The wind is rarely uniform;
- The area over which wind information can be obtained is limited to regions with targets (like rain, bugs, etc.) because the measurement of the radial velocity is possible only if there is a target to measure the speed of;
- The height at which radar observes the weather increases with distance because the radar generally points at some elevation over the horizon.

Despite these limitations, Doppler information is of great value for weather forecasters especially in severe weather where:

- rotation signatures - indicative of risk of tornado, and
- divergence signatures - indicative of strong downdrafts when observed near the surface can be identified.



RADAR BASICS

Storm-relative Velocity vs Base Velocity

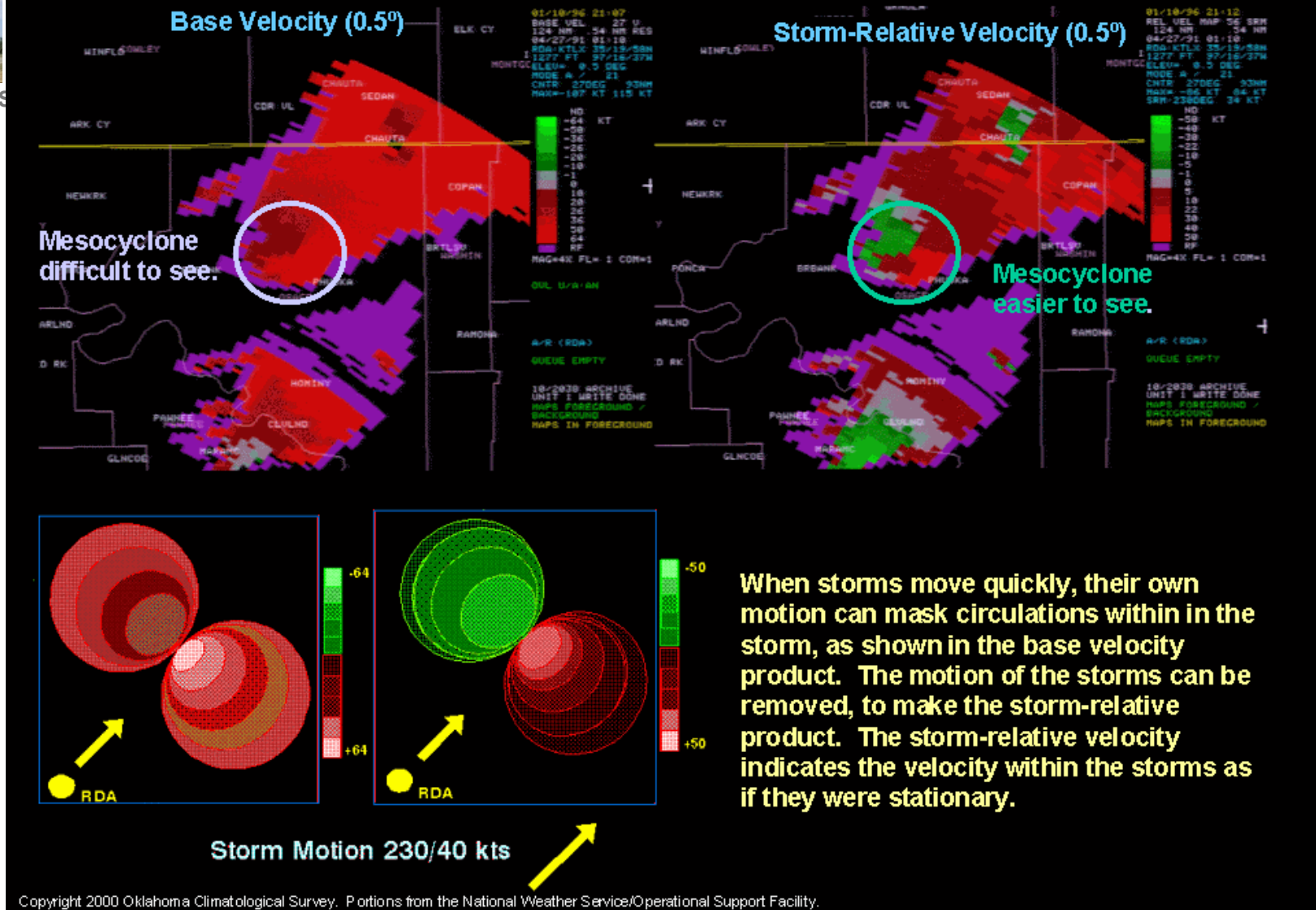



RADAR BASICS

AZIMUTH RESOLUTION

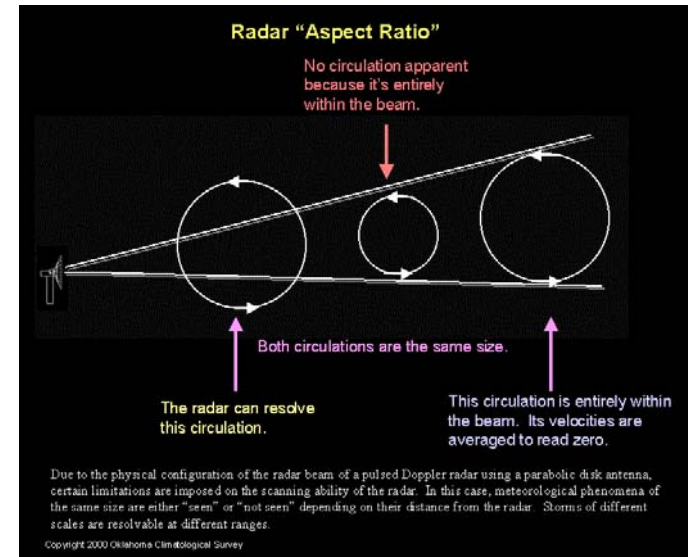
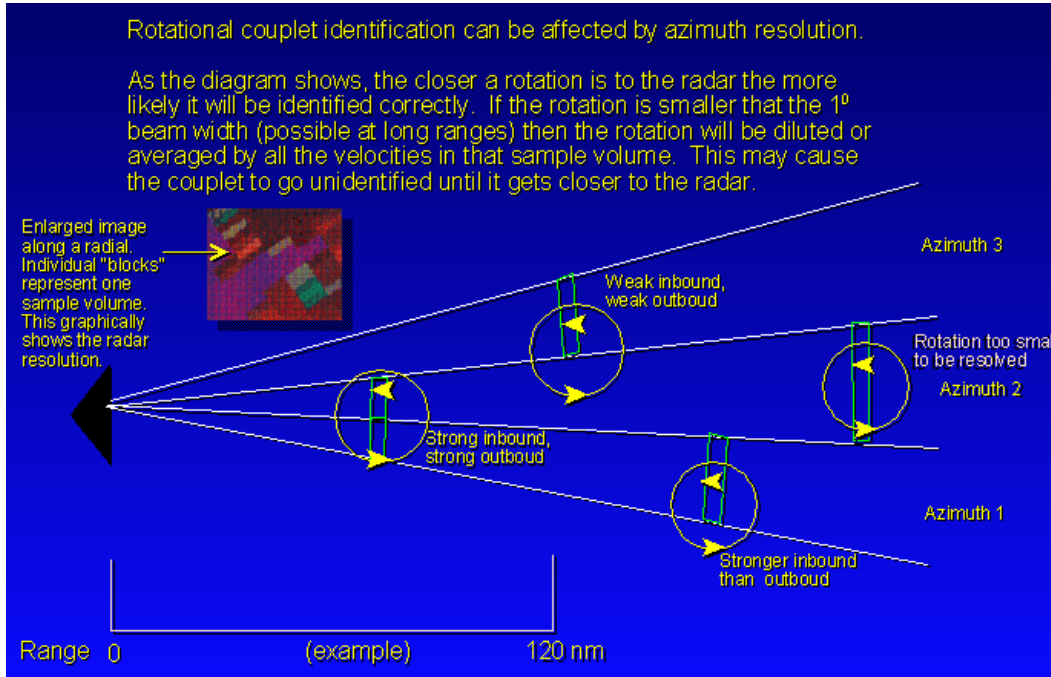



RADAR BASICS

Velocity Azimuth Display - VAD Method

As we have seen, Doppler radar allows the measurement of only one (radial) component of the velocity of the targets. In general case, air movement is 3-dimensional and varies over time and space.

Simultaneous measurements with three Doppler radars would have to be performed to describe this movement completely, but typically only data from a single Doppler radar are available.

That is why we are forced to make simplifying assumption on the structure of the observed wind field during creation of Doppler products.

The most simple case is to consider a horizontally uniform wind field for both, horizontal and vertical (precipitation fall velocity), components.

In such a case, if we make measurement of the velocity along circles centered at the radar by azimuthal scanning at a constant elevation angle (PPI), we get for a constant distance from the radar sinusoidal dependency of the measured radial velocity on the azimuthal angle.

Direction of horizontal wind β_0 is given by azimuths of the maximum and minimum measured radial velocity. Horizontal $[(V_h)]$ $(v_1 - v_2) / 2 \cos \alpha$ and vertical $[w]$ components of the velocity speed is obtained from maximum ($V_1 = V_{rmax}$) and minimum ($V_2 = V_{rmin}$) velocity and elevation angle α $(v_1 + v_2) / 2 \sin \alpha$.

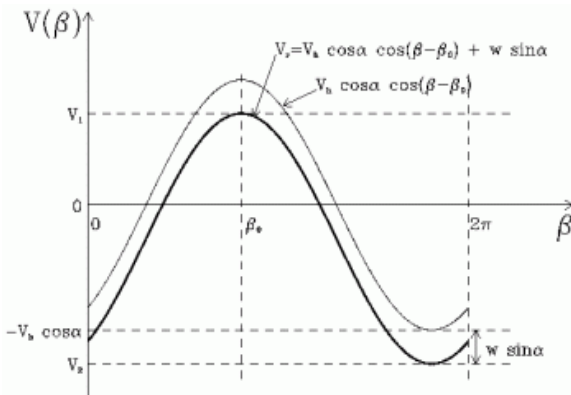
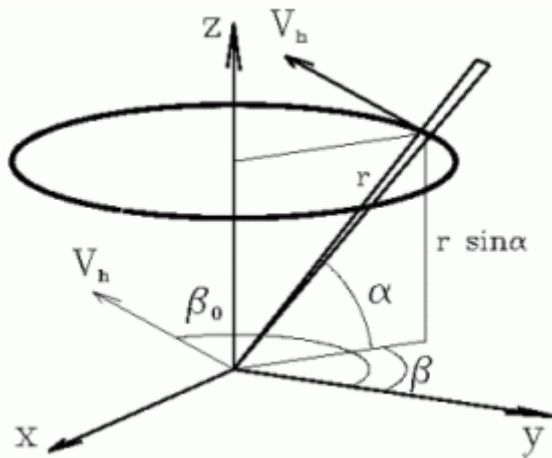



RADAR BASICS

RANGE-VELOCITY AMBIGUITY



RADAR BASICS

Maximum Unambiguous Range (R_{max}) vs. PRF

One of the primary reasons for sending out discrete pulses of E-M energy at given time intervals is that this allows for target ranging.

The listening period is the time from when the radar finishes transmitting the first pulse to when it begins transmitting the second pulse. This period allows the first pulse to travel a certain round trip distance. This distance when divided by 2 yields the maximum unambiguous range (R_{max}) of a radar. R_{max} can be expressed mathematically as

$$R_{max} = \frac{c\tau}{2}$$

where c = speed of light ($\sim 3 \times 10^8 \text{ ms}^{-1}$) and t = listening period (s). Since the pulse duration is very small (msec) when compared to the PRT (msec), R_{max} can be approximated by substituting the PRF or PRT for t .

$$R_{max} = \frac{c}{2PRF} \quad \text{or} \quad R_{max} = \frac{cPRT}{2}$$

where PRF = pulse repetition frequency (s^{-1}) and PRT = pulse repetition time (s) = $1/PRF$



RADAR BASICS

Maximum Unambiguous Velocity (V_{max}) vs. PRF

Not only is R_{max} dependent on the PRF, but so is the maximum unambiguous velocity (V_{max}) that the WSR-88D can determine for a volume of targets.

By "unambiguous", we are referring to the WSR-88Ds ability to accurately determine the largest Doppler radial velocity with its "first guess" or pass through the data. The relationship between V_{max} and PRF can be expressed mathematically as

$$V_{max} = \frac{\lambda PRF}{4} \quad \text{or} \quad V_{max} = \frac{\lambda}{4PRT}$$

where PRF = pulse repetition frequency (s^{-1}); PRT = pulse repetition time (s) = $1/PRF$

and λ = wavelength of energy transmitted

For a PRF = 1000 pulses/sec (or PRT = .001 s) and λ = 0.105 m (or 10.5 cm), V_{max} is 26.25 ms^{-1} (or ~ 51 kt).



RADAR BASICS

DOPPLER DILEMMA

The combination of maximum unambiguous velocity and maximum unambiguous range form two constraints which must be considered in choosing the PRF for use with a Doppler radar.

$$V_{max} = \frac{\lambda}{4PRT} \quad \times \quad R_{max} = \frac{cPRT}{2} \quad = \quad V_{max} R_{max} = C \lambda / 8$$

Range folding is the placement of an echo by the radar in a location whose azimuth is correct, but whose range is erroneous (but in a predictable manner). This phenomenon occurs when a target lies beyond the maximum unambiguous range of the radar (R_{max}).

Reducing the pulse repetition frequency (PRF) and allowing for a longer listening time will alleviate the problem of range ambiguities (or folding or aliasing).

For example, for a S-band radar, if the PRF is 1000 Hz, the maximum unambiguous range is 150 km while V_{max} is +/- 25 m/s. For a X-band radar using the same PRF, R_{max} is still 150 km, but V_{max} is now only +/- 8 m/s.

For meteorological situations, we may want to measure velocities as large as +/- 50 m/s out to ranges beyond 200 km, so neither of the limits calculated above is completely adequate.



RADAR BASICS

The ***Doppler Dilemma*** is caused by physical restrictions. One of the ways to work around this dilemma is to operate at variable PRFs, collecting reflectivity information at low PRFs and velocity information at high PRFs. The two sets of information collected are compared and processed to estimate true radial velocities and ranges.

Velocity detection is wavelength dependent. As soon as the one-half wavelength limit is passed, the determination of velocity becomes ambiguous. Anytime we speak of wavelength, the same arguments hold for frequency, since they are inversely related.

Ultimately, the pulse repetition frequency (PRF) of a radar determines the maximum speed that can be detected without confusion. The maximum unambiguous velocity that can be detected at a given PRF is called the *Nyquist velocity*.

Nyquist intervals are those velocities from zero up to the Nyquist velocity.

The **Nyquist co-interval** is the entire range of detectable velocities both negative and positive. For example, if the **Nyquist velocity** is 25 knots, then the Nyquist interval is any velocity from 0-25 knots, and the Nyquist co-interval is -25 through +25 knots.

DEFEATING DOPPLER DILEMMA – The volume coverage pattern are organized in a way of the lowest elevation scans are sampled twice in low and high PRF, the middle scans are performed in alternating low and high PRF and the upper elevation in high PRF.



RADAR BASICS

EFFECTS ON THE DOPPLER SPECTRUM



RADAR BASICS

SPECTRUM WIDTH

When a radar detects a single target, the frequency shift in the returned signal is given by:

$$fd = 2V / \lambda$$

where fd is the Doppler frequency shift, V is the radial velocity of the target and λ is the wavelength.

When there are many targets within the sample volume, each individual target would produce a frequency shift related to its radial velocity.

The result is that a distribution of frequencies would be measured.

In a real radar sample, there would be billions of raindrops present.

A Doppler radar usually processes all the returned signals to produce a single velocity for the entire sample volume.

This is the mean velocity of the sample and is what we usually mean when we talk about the Doppler radial velocity.

Is a measure of the dispersion of velocities within the radar sample volume, and it is computed by the standard deviation of the velocity spectrum.



RADAR BASICS

As seen, phase is one of the basic measurements that can be made on radar signals, it is necessary to determine the accuracy of phase measurements.

How can we measure its variance?

Considering the input signal a narrow band Gaussian:

With the radar signal broken into real and imaginary components, we can note that the tangent of the **phase (f)** of the signal is just the ratio of the imaginary over the real component, that is: **$\tan(f) = \text{Imaginary} / \text{Real}$**

In radar terminology, which relates to the phase of a signal relative to some reference frequency, the **real part is called inphase**, and the **imaginary part is called quadrature**.

The quadrature refers to the 90 degree phase shift, one quarter of a circle. Then,

$$\tan(f) = \text{Quadrature} / \text{Inphase}$$

Now with the definition of phase, we can look at the signal and the noise.

We will establish a signal vector with power S. The amplitude of the vector is square root of S. We will set the signal so that it lies coincident with the inphase axis.



RADAR BASICS

Although this does not appear to be general, this is just a rotation of coordinate systems and will yield identical results independent of signal vector angle. It is much easier to visualize if the signal vector is fixed, and the coincidence of the signal vector with inphase enables easy understanding.

Noise is only a little more difficult to visualize. The key to noise is to know that narrowband noise can be represented by putting half the noise power N inphase and half in quadrature, so that each has power $N/2$.

The inphase and quadrature noise vectors are independent of each other, and are identically distributed Gaussian random variables. The standard deviation of the noise in each channel is *square root*($N/2$).

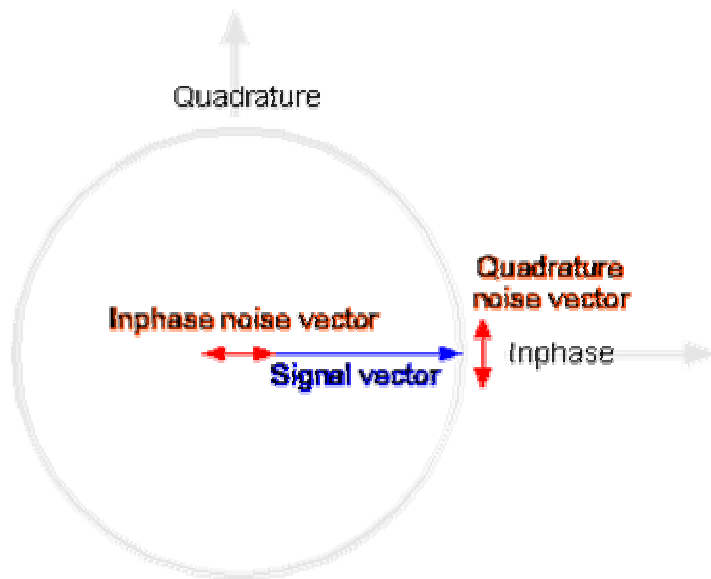

The inphase component of the noise does have an effect on the phase, but it is a second order effect.

For any SNR that would be used in radar detection, the inphase noise has no impact on the phase measurement.



RADAR BASICS

Since we are concerned with phase only in this problem, we will drop further consideration of the inphase noise for this problem only. With this, the phase can now be approximated as

$\tan(f) \gg \text{Quadrature Noise} / \text{Signal}$

$$\sigma_{noise}^2 = N$$

$$\sigma_I^2 = \sigma_Q^2 = N/2$$

$$\sigma_{\theta} = \sigma_{\phi} = \sqrt{N/2}$$

$$\text{Signal} = \sqrt{S}$$

For f small, $\tan(f) \sim f$. This is equivalent to $S \gg N$.

Because this is required for detection, the approximation is valid in all cases of interest.

$$\sigma_{\theta} = \frac{\sqrt{N/2}}{\sqrt{S}} = \frac{1}{\sqrt{2 \cdot SNR}}$$

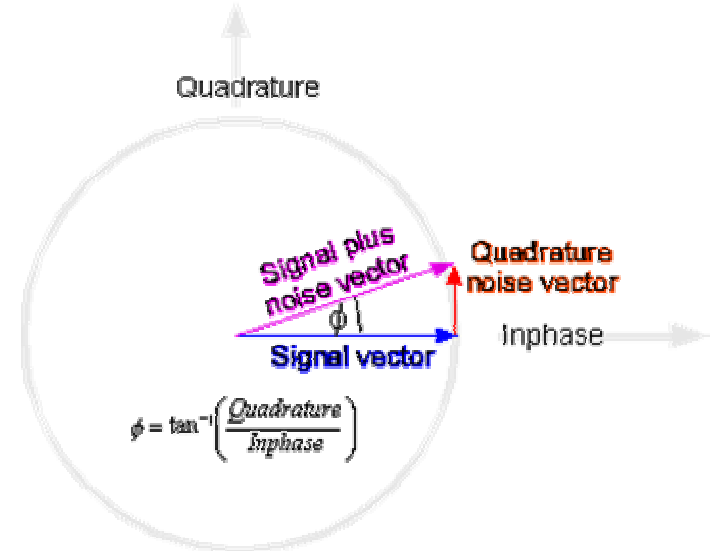

The variance of the mean radial velocity is proportional to the variance of the Doppler frequency shift.



RADAR BASICS

GROUND CLUTTER REJECTION TECHNIQUES



RADAR BASICS

THE CLUTTER PROBLEM

The Earth is also a pretty good object for sending signals back to the radar.

If you point the radar at the ground, you'll get a strong signal. So naturally most people don't point the radar at the ground.

But that doesn't solve the ground clutter problem, because if you point the radar low to the ground, part of the beam will intersect the ground and produce a return signal. On the other hand, if you point the radar well above the ground, you miss seeing all of the precipitation near the horizon at larger distances from the radar.

The weather services radars take advantage of a useful fact: the ground doesn't move. Thus, the ground clutter falls into a known pattern which repeats itself.

Also, the Doppler velocity of the ground clutter is zero.

The radar processors use this information to detect and identify ground clutter and remove it from the display. These techniques are not perfect, though, so you should be alert for radar echo patterns which don't move.



RADAR BASICS

Weather Radar Clutter - There is a wide range of other reasons (some can be quite strange) why returns and echoes can be received at the weather radar antenna. Some examples are presented here:

Insects & Bugs - perhaps clouds of them. Clearly, insects and bugs will provide some level of reflections (especially at lower elevations near the land). These can be useful as 'tracers' which could for example track low-level winds such as sea breezes. Insect returns are most common closer to the weather radar station.

Dry roll convection in the boundary layer - this is a phenomenon which is mostly only detectable by clutter from insects and birds. When conditions are just right, there can be 'dry thermal plumes' of rising warm, moist air in the lowest few hundred meters of the atmosphere. These will often form into long, 'rolls'. They are very difficult to detect (unless potentially using reflections from bugs and birds, etc.). This can therefore be defined as a phenomenon.

Sea Clutter - Under certain wind and other atmospheric conditions, sharp-tipped waves can reflect microwave energy back to the radar; this phenomenon is known as sea clutter. Sea clutter can be of modest to large reflectivity and extend to long ranges. It can complicate 'near-surface' velocity analysis by returning a mix of both the wind and wave motion. It is common that sea clutter is caused by atmospheric refraction and the climatic conditions near the coast are particularly susceptible to this.

Ships - Sea Clutter patterns can be disrupted by passing ships.



RADAR BASICS

Bird migration - Strange but logical. The returns from flocks of migrating birds will show up at weather radar systems - this phenomenon is often referred to as Angel Echo. Bird reflections can be quite troublesome in radar meteorology. It only takes one bird per volume to return a large, moving radar echo. During the migration season, the effect can be quite serious. However, using Doppler techniques, the radial velocity of migrating flocks of birds will normally fall into a specific category.

Anomalous propagation - Under certain atmospheric conditions, the refractive index of air can change with height in such a way as to bend the transmitted beam back down towards the surface; it then hits the ground, and returns along its curved path to the radar. This is commonly known as anomalous propagation.

Chaff - Military system to disperse many small reflective particles into the atmosphere. These disperse and slowly fall to the ground. They are high reflective and are essentially used to 'jam' the radar display.

Aircraft - For a weather radar, reflections from aircraft passing through the airspace will be considered as clutter.

Radome Clutter - The effects of a radome can increase the general clutter, noise and interference received at the antenna. etc.



RADAR BASICS

Clutter Processing

This page provides an overview of some of the techniques that are commonly used to eliminate clutter and unwanted reflections within a weather radar system to allow a smoothed view of the objects of interest to be constructed. There are a wide range of methods (and algorithms) defined to allow for the different types of clutter to be discriminated and disregarded from the useful returns. These include:

Clutter Map (processing)

A clutter map can be generated for a specific primary radar installation that identifies the expected levels of unwanted returns from **non-fluctuating** obstructions to the radar beam.

Doppler processing

Doppler processing is commonly used to identify returns from moving objects and provide a figure for their radial velocity (or velocity relative to their distance towards or from the radar). Its weakness however is that it can only detect velocity of an object in one plane.



RADAR BASICS

Polarization (reduction)

Polarization techniques are used to detect the 'direction' of the electric field (E) of the electromagnetic wave. There are linear and circular polarisation techniques known. In weather radar, Polarimetric weather radar systems (although still Doppler radars) measure dual polarization in the horizontal and vertical planes and use this information against another set of recorded characteristics (e.g. look up table) as another indicator of the type of the weather.

Linear Polarization (most suitable in clear weather conditions) and circular polarization (most suitable for use in precipitous weather conditions) are used primarily by PSR systems. Their use is optimized to remove weather clutter.

Dual Polarization (horizontal and vertical) together provide the differential reflectivity of weather (which can be used to identify weather types). Polarization techniques are now becoming common in today's weather radar systems.

Other Clutter Processing and Reduction Techniques

The above issues will be examined in more detail in the module „Radar Basics“. It is noted however that a considerable number of other techniques for the processing and reduction of clutter are also defined and used in some radar implementations (for example, statistical analysis techniques). These are not examined in detail in this module.



RADAR BASICS

DUAL POLARIZATION RADAR



RADAR BASICS

Another method for hail detection uses dual polarization. The radar transmits and receives linear polarized signals and switches rapidly between horizontal and vertical polarization, either between individual pulses or groups of pulses.

More modern polarimetric radar units send even both polarization directions simultaneously.

$$ZDR \sim 10 \log (Z_h / Z_v) [dB]$$

where:

Z_h is the returned horizontally-polarized backscattered power received from the horizontally-polarized transmitted pulse.

and:

Z_v is the returned vertically-polarized backscattered power received from the vertically-polarized transmitted pulse



RADAR BASICS

The two returns are referred to as Z_H and Z_V and from these the differential reflectivity Z_{DR} is calculated.

In moderate to heavy rain the rain drops are large and as they fall they flatten to become oblate spheroids, giving a stronger echo for horizontal polarisation.

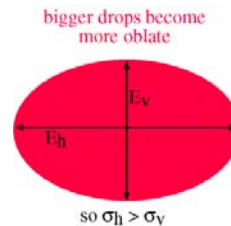

The dielectric constant of solid ice is about 20% of that of water and therefore particle shape has a much smaller effect in hail than in rain. Also hail particles tumble as they fall so ZDR will be small.

Hail is identified by high Z_H and low ZDR. If even ZDR results less than one should appear (or a negative deciBel- value), this is a typical sign for hailstones. Only these can fall down in vertical orientation finally!



RADAR BASICS

DERIVATION OF POLARIMETRIC RAINFALL ESTIMATORS

Polarimetric radar measurements and rainfall estimates derived from them are sensitive to the radar-apparent mean shape of rain drops illuminated by the radar beam. Oscillating drops in the free atmosphere tend to be more spherical in the mean than the equilibrium shapes used in many studies.

An axis ratio relationship developed from a number of published observation studies is:

$$r = 0.9951 + 0.02510D^1 - 0.03644D^2 + 0.005030D^3 - 0.0002492D^4$$

Using this relationship, available disdrometer measurements, and T-matrix calculations of scattering cross-sections, calculations were made for radar reflectivity at horizontal polarization (ZH), specific differential phase (KDP), differential reflectivity (ZDR), and the rain rate (R).

The following set of fixed-form polarimetric rainfall estimators was then derived:

Radar Reflectivity: $R = 2.62 \times 10^{-2} ZH^{0.687}$

Specific Differential Phase: $R = \text{sign}(KDP) 54.3 |KDP|^{0.806}$

Spec. Diff.Phase/Diff.Reflectivity: $R = \text{sign}(KDP) 136 |KDP|^{0.968} ZDR^{-2.86}$

Radar Reflectivity/Diff.Reflectivity: $R = 7.46 \times 10^{-3} ZH^{0.945} ZDR^{-4.76}$



RADAR BASICS

DUAL FREQUENCY RADAR



RADAR BASICS

Dual Frequency Radar

This method requires the use of two wavelengths, one long enough for Rayleigh scattering, the other short enough for non-Rayleigh, or Mie, scattering to occur in the presence of large hydrometeors such as hailstones.

Typical wavelengths are 10 cm and 3 cm (S-band and X-band). If the radar reflection in dBZ is similar for both wavelengths then the echoes are from small hydrometeors, but if the 3 cm reflection is less than the 10 cm large particles are present.

This is indicative of hail because there are rarely large rain drops.

However errors can occur with this method due to the difference in attenuation at the two frequencies, the shorter wavelength will suffer more attenuation.

Correction algorithms may be used but hail, rain, dry and wet snow all have different attenuation rates and this can introduce a distortion of the results leading to false hail declaration.

Space based radars are designed to use X and K band systems.



RADAR BASICS

CLEAR AIR TARGETS



RADAR BASICS

CLEAR-AIR DATA

Originally, "clear-air" echoes were called "angel", or "ghost" echoes

There are two possible scattering mechanisms possible:

1. Scattering from refractive index gradients on scale of $l/2$

This is often referred to as "Bragg Scattering" $\eta \propto \lambda^{-1/3}$ for Bragg scattering

This suggests using long wavelengths to more effectively detect refractive index gradients.

2. Particulate scattering from insects and birds

- Then have rayleigh scattering where $\eta \propto \lambda^{-4}$



RADAR BASICS

THE EFFECT OF BIRDS AND INSECTS

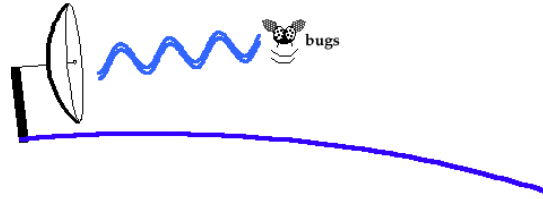

To a radar, birds are just large balls of water with feathers. It doesn't take many birds to produce a good signal for the radar. Insects also contain water, and since they are much smaller it takes a lot more insects to produce a signal. The radar cross-section for small birds at 10 cm wavelength is about 10 cm², for large birds is of the order of 2000 cm² at short range.

During the migratory seasons, the birds can essentially fill the radar volume at low levels. There may be a preferred altitude, or the birds' density may just decrease steadily upward. The reflectivity pattern will take the form of a fuzzy disk or ring, centered on the radar.

Insects present large targets to radar and they are always present during the warmer seasons. This actually is beneficial to meteorologists. Doppler radars require targets to determine the motion of the air.



RADAR BASICS

Outside of regions where precipitation is falling, there would be no targets if there were no insects.

Airborne insects turn out to be very good tracers of air motion since, on average, they blow along with the wind.

The returns from insects allow meteorologists to see air motions outside the storm circulation which in many cases is important for predicting where new storms are likely to occur.

Radar echoes in a clear atmosphere will be more common on days when the lower atmosphere is unstable, as when there are thermals present, or when the wind increases rapidly with height just above the ground, so that there is mechanical turbulence.

AN INSECT RADAR EXPERIMENT

It was a collaborative effort between the US Department of Agriculture and NSSL in the late seventies. USDA was in the process of specifying a special purpose radar for tracking insects-particularly harmful insects and the experiments determined the radar cross section of a select group of prime interest.



RADAR BASICS

The researchers team hatched the insects in a leased hanger on Westheimer Field, sterilized them and released them from a light aircraft.

They tackled the insects with the Norman Doppler and from known radar parameters, range, etc; and insect concentration estimated the radar cross section.

The measured cross sections for a wavelength of 10 cm and horizontal polarization ranged from 0.25 (10⁻³) cm² for the boll weevil to 8.1 (10⁻³) cm² for the corn earworm.

The required target detection was used in conjunction with other requirements to specify performance of the special purpose radar.

The radar worked quite well and was used in a number of experiments mostly in the "Big Bend" area of Texas.

Among other experiments it was used to monitor and track insect migration. Migration was then related to weather conditions (surface observations, soundings, etc;) from which prediction models were developed.

The models are used to issue advice on when and where to apply pesticides for crop protection.



RADAR BASICS

TURBULENCE

Turbulence provides another way in which electromagnetic energy from a radar can be back-scattered. Turbulence is associated with variations in density in the atmosphere.

When variations in density occur on a scale of half the wavelength of the radar, energy is scattered through a process called diffraction.

The speed at which electromagnetic waves travel between a radar and a target is dependent on the index of refraction of the atmosphere between the radar and the target.

Small changes in the time it takes a radar signal to travel to a fixed target and back are related to small variations in the refractive index caused by changes in humidity, temperature, and pressure.

The measurement of the refractive index therefore opens the possibility of extracting information of surface conditions (especially humidity) by radar.

Using the phase information from ground targets and its time evolution as a proxy for the travel time of radar waves, a procedure for measuring the near-surface index of refraction field around the radar was demonstrated and implemented.



RADAR BASICS

An example from the J.S. Marshall Radar Observatory McGill University

The result of this collaborative work between McGill and NCAR can be readily implemented to any Doppler radar, provided the transmitter's stable local oscillator (STALO) has accurate (below 0.25 ppm) frequency stability over very long periods (months or a few years) and that the phase of the targets are measured.

Accurate measurements of refractive index fields in a radius of a few tens of kilometers around the radar (where ground targets can be observed) are being made, and contrasts in refractivity associated with front passages and storm outflows have been observed (Fabry et al. 1997). Occasionally, convection initiation occurs on sharp boundaries of refractivity.

An evaluation of these refractivity contrasts in the Montreal area (Creese 1999) shows that 74% of the variability in refractivity is caused by variability in moisture.



RADAR BASICS

Hence, if a reasonable assumption is made for temperature and pressure in the area observed, fields of moisture can be obtained with an accuracy of 0.3°C in dew point.

The refractivity (or refractive index) product uses the phase of ground targets to detect minute changes in the speed of radar waves between the radar and ground targets.

From this information the refractivity of the air near the ground is determined.

Since refractivity is closely linked to air density (and hence temperature) and especially to moisture, the measurement of refractivity could provide valuable information on surface conditions around the radar.

Because of the limited range up to which ground targets can be observed regularly, the maximum useful range of the refractivity measurement is of the order of 30 to 40 km.

The value of the refractivity field information for meteorological purposes is still being evaluated since this product is a recent development.



RADAR BASICS

a) Weather observations

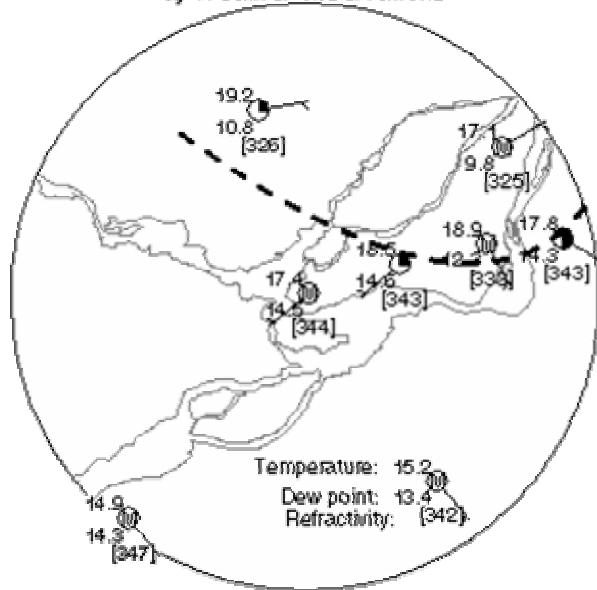

b) Refractivity field derived from radar data

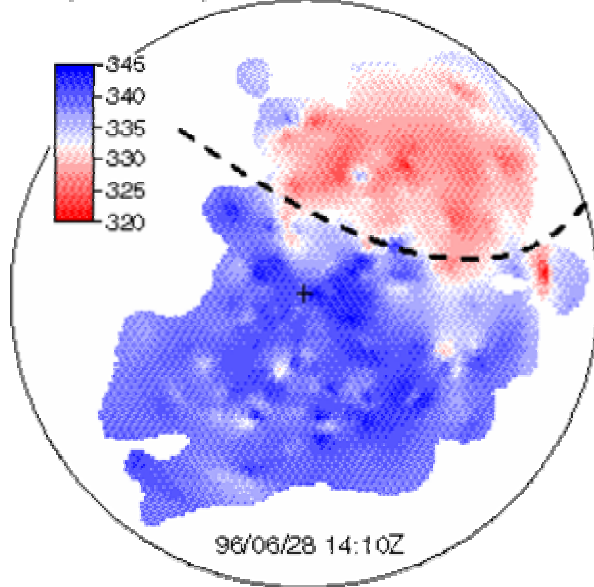

In this example, the refractivity field measured by radar (bottom) is contrasted with simultaneous weather observations over a range of 45 km. Two air masses can be identified, a drier one to the north (10°C dew point temperature) and a wetter one to the south (14°C dew point temperature).

The refractivity computed using surface observations (shown in brackets in the upper window) match well the refractivity measured by radar.

While the presence of a gradient in moisture could have been inferred from surface observations alone, the radar measured refractivity allow the precise determination of the position of the boundary between the two air masses (shown with heavy dashes).



RADAR BASICS

QUALITY-CONTROL OF RADAR REFLECTIVITY - RAINFALL DATA



RADAR BASICS

Radar reflectivity data is subject to many contaminants. Not all reflectivity corresponds to "true" weather.

It is important to remove as many of these problems as possible and provide a cleaned-up field for applications such as weather tracking and precipitation estimation. **Quantitative Precipitation Estimation (QPE) algorithms** needs **high Quality Controlled data**.

Among the problems that radar reflectivity is subject to are:

Ground clutter - Since the radar beam is at a low height close to the radar, ground clutter can contaminate echo close to the ground.

Anomalous propagation - Even though the radar beam is pointed upward, in certain atmospheric conditions, the beam can be tilted downward and end up sensing tall buildings or the ground.

Beam spreading and attenuation - Both combine to produce a much poorer sampling of storms far from the radar.

Bright-band contamination - As the beam crosses the melting layer, reflectivity is biased upwards, often as much as by 5dBZ.

Receiver calibration and maintenance – adequate calibration process including loss factors and control strategies, with the system calibration monitored regularly from a central point – it is also fundamental for Doppler.

Quantitative intercomparison – using networked radar data or other sensors measurements



RADAR BASICS

SPACE BASED RADARS



RADAR BASICS

Global Precipitation Measurement (GPM) Observation Concept

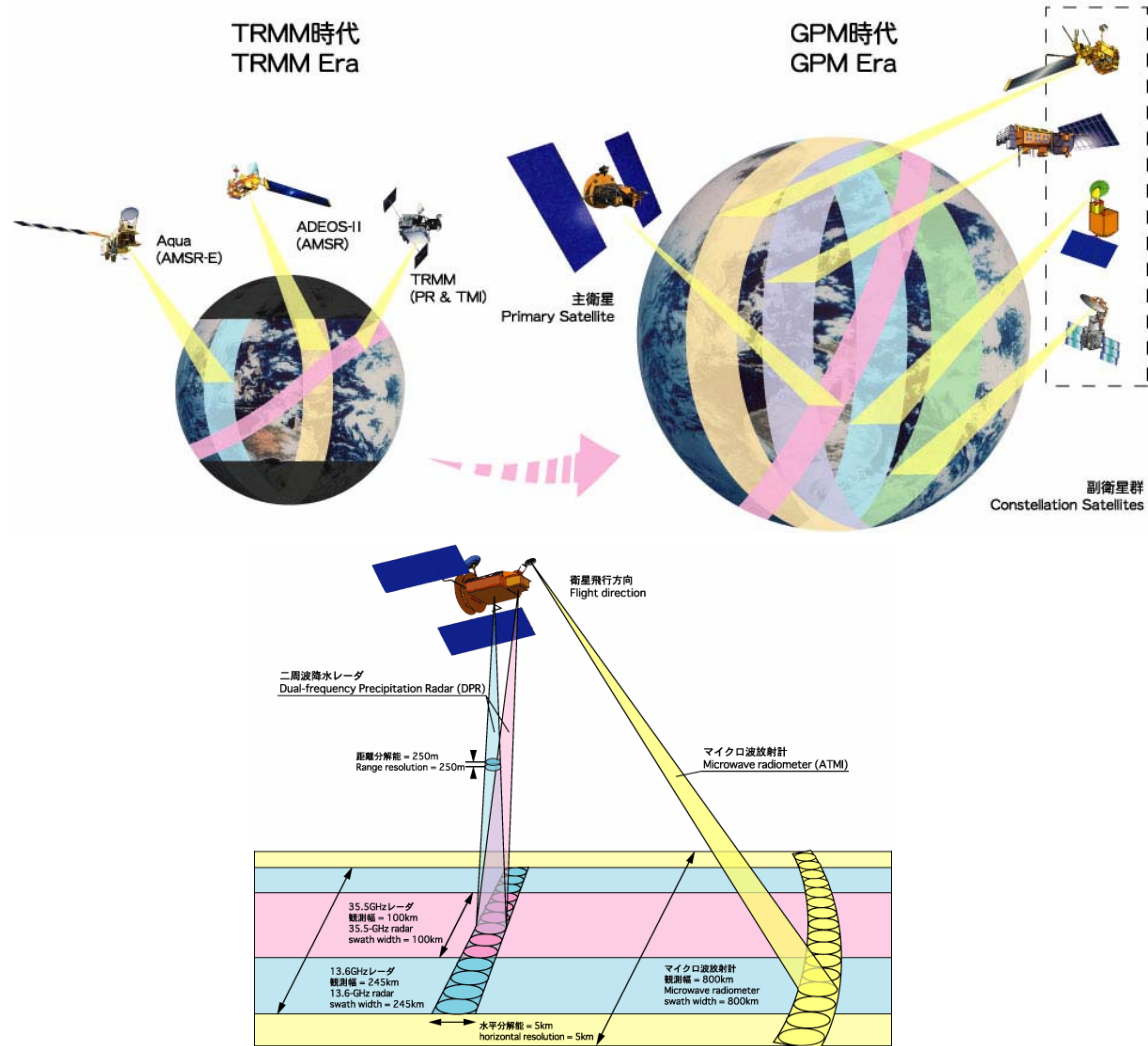



RADAR BASICS

Precipitation Measurement with Dual-frequency Precipitation Radar

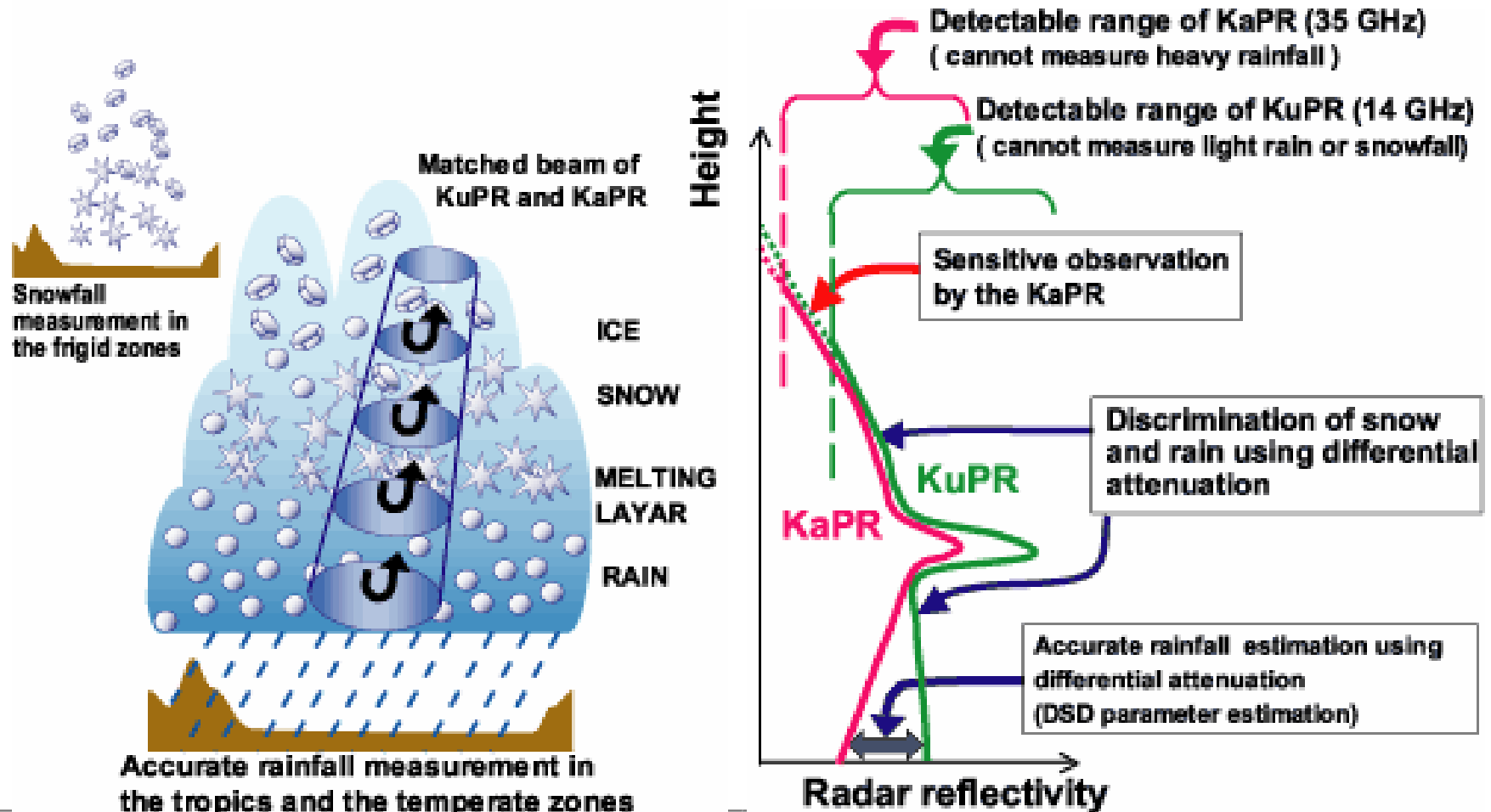



RADAR BASICS

"The work of Battan, Bowen, and other pioneers in radar meteorology changed the whole field of cloud physics, solving some old puzzles but opening enough new ones to keep their successors busy for decades"

W.F. Hitschfeld, McGill University 1986

...still valid today!

